

PTN.	DESCRIPTION
1A	CEMENT CASE
1B	SPINDLE SEAL
1C	CEMENT CASE COVER
1D	PERIMETER GASKET
1E	CASE COUPLER F/PAIRS
1F	COUPLER COVER F/SINGLES
1G	CONDUIT CONNECTOR
2A	SLED BASE
2B	MOTOR MOUNT BRACKET ASSY
2C-T	FRONT PIVOT HOUSING RISER
2D-T	REAR PIVOT HOUSING RISER
2E	BASE PLATE
2F/G	TOP PLATE/LAT BUSHING
2H	CHAIN TENSION STOP BOLT
2H-1	CHAIN TENSION ANGLE
2J	BASE PLATE BOLT
2K	LATERAL WEDGE
2L	LATERAL HEX WEDGE
3A	PIVOT ARM SPINDLE
3B	SPINDLE SPROCKET
3C	SHAFT KEY
3D-1	STD. ANTI-SLIP COLLAR F/KEY
3D-2	ALT. ANTI-SLIP COLLAR F/KEY
3E	"O" -RING
3F	BEARING COVER
3G	THRUST BEARING
3K	THRESHOLD SEAL
3L	"O" -RING SEAL
3M	ONE-WAY RETAINING RING (2)
4A	DRIVE SPROCKET - SPLINED
4B	THRUST WASHER-THICK
4C	NEEDLE BEARING
4D	THRUST WASHER-THIN
4E	SPACER
4F	FLAT WASHER
4G	HEX BOLT
5	DRIVE CHAIN OR BELT
6	THRESHOLD ASSY.
7	OPERATOR ASSY.

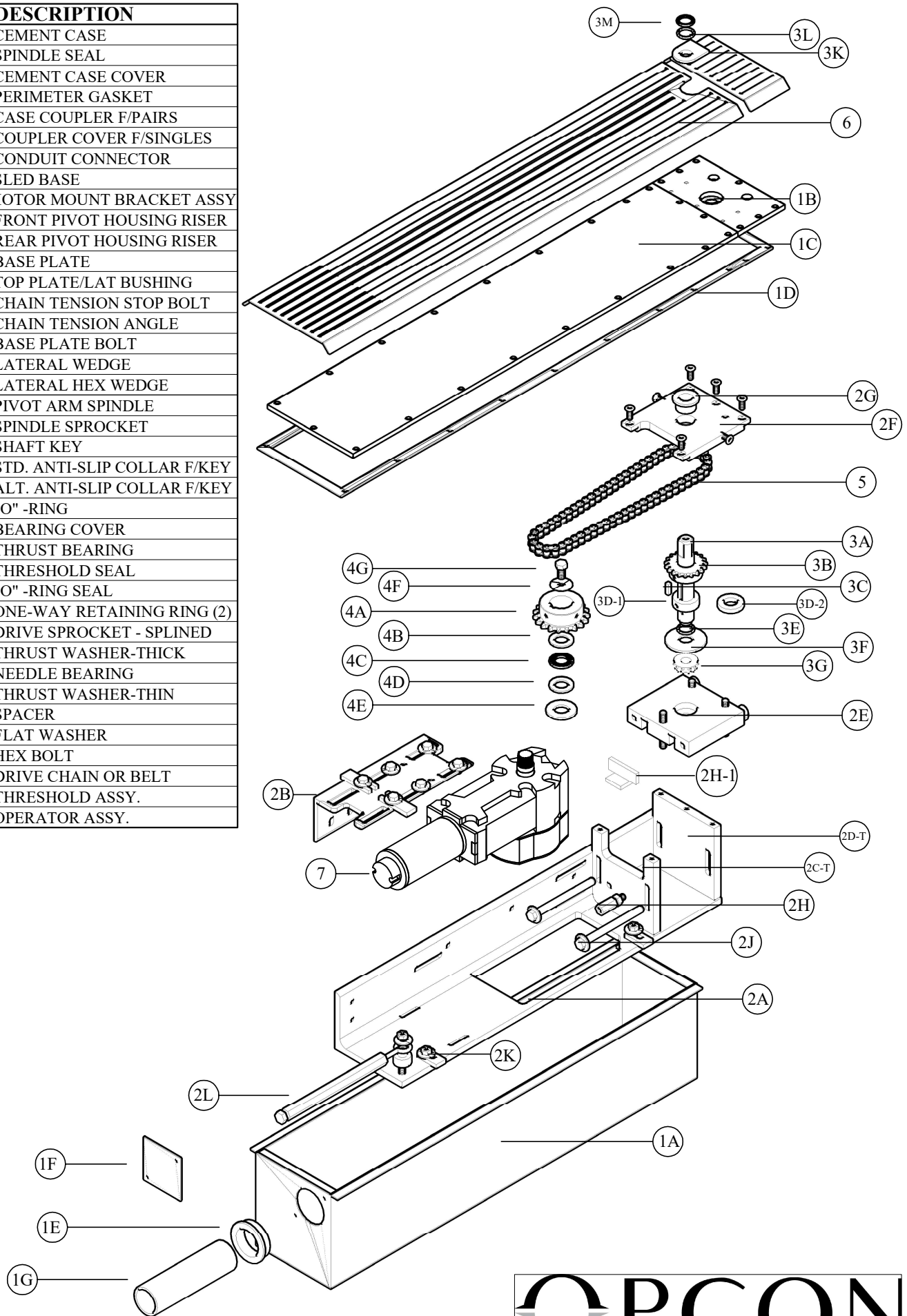

DORMA ED400-IG ISOMETRIC