

ASSEMBLY & INSTALLATION MANUAL

OPCON IN-GROUND CONVERSION KIT FOR STANLEY MAGIC FORCE

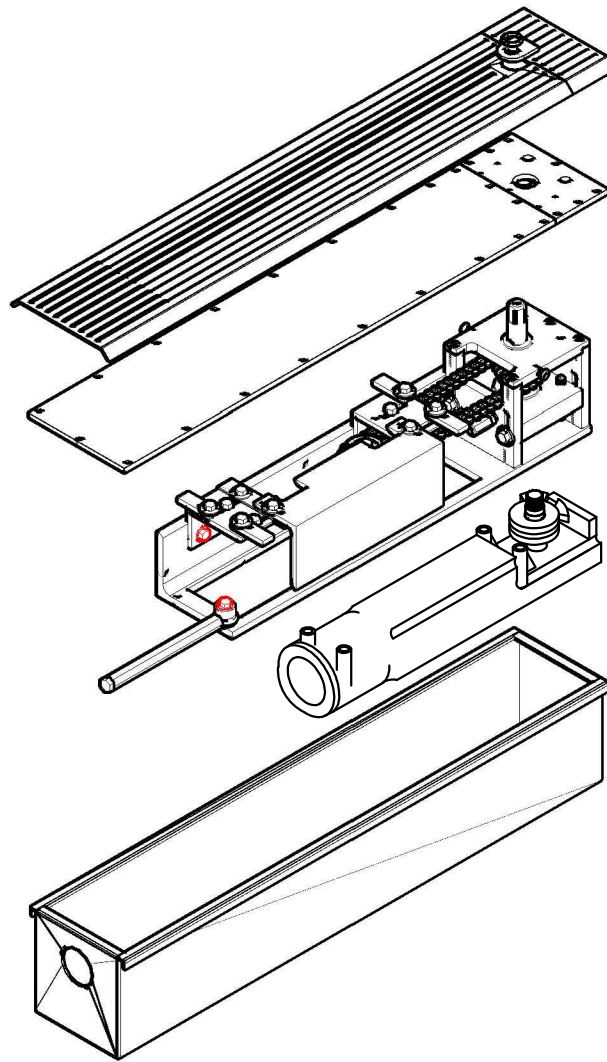

Go to www.opconusa.com for shop drawings, architectural details, technical details, hardware, product links and other related information.

INDEX

<u>TITLE</u>	<u>Page</u>
THEORY OF OPERATION & IMPORTANT CONSIDERATIONS	3
ISOMETRIC DRAWING WITH PARTS IDENTIFICATION	4
 <u>ASSEMBLY PROCEDURE</u>	
OPERATOR ASSEMBLY (Procedure 1)	5
CHAIN AND SPROCKET ASSEMBLY (Procedure 2)	6
CHAIN TENSIONING & TUNING (Procedure 3)	7
SPINDLE CENTERING & WEDGING (Procedure 4)	8
SPINDLE HEIGHT ADJUSTMENT (Procedure 5)	9
 <u>SEALING</u>	
CEMENT CASE & SPINDLE SEALS (Procedure 6)	10
 <u>FLOOR BLOCKOUT TEMPLATES</u>	
CENTER HUNG	11
3/4 " OFFSET PIVOT HUNG (Standard Arms – Under Jamb Mount)	12
BUTT HUNG (HINGED) (Bottom Slide Arm – Within Jambs)	13
 <u>INSTALLATION PROCEDURES</u>	
CENTER HUNG DOORS	14
3/4 " OFFSET PIVOT HUNG DOORS (Under Jamb Mount)	15
BUTT HUNG (HINGED) DOORS	16
 <u>WIRING AND ELECTRICAL</u>	
ELECTRIC & LOW VOLTAGE CONDUIT CONNECTIONS	17
WIRING REQUIREMENTS – LIQUID TIGHT FITTING DETAILS	18
WIRING REQUIREMENTS – STANDARD INSTALLATION	19
WIRING REQUIREMENTS – ELECTRIC PANIC DEVICE	20
WIRING REQUIREMENTS – OVERHEAD ELECTRIC LOCK	21
WIRING REQUIREMENTS – BOTTOM ELECTRIC LOCK	22
WARRANTY	23/24

OPERATOR CONVERSION THEORY & IMPORTANT CONSIDERATIONS

(REVIEW BEFORE STARTING ASSEMBLY AND INSTALLATION)

THEORY OF OPERATION

The Opcon Operator Conversion System is designed to convert standard overhead mounted, swing door operators from overhead mounted to underground/underfloor use. A custom pivot assembly and operator-mounting sled is provided to attach the standard operator, creating a new drive assembly. The entire drive assembly is then placed into a waterproof cement case, sealed, and cemented into place under the door. The drive system Spindle attaches to the bottom arm of the door. The Spindle profile of the unit integrates with many available bottom arms for center hung and offset hung swing doors.

CONSIDERATIONS

- 1) **HANDING:** It is important to note that handing the operator is opposite of standard since the operator is mounted upside down when converted. Specifically, a left hand operator swings a right hand door; and a right hand operator swings a left hand door. Microswitch placement, stop block placement, and programming functions will be affected depending upon the operator selected.
- 2) **DRIVE SPINDLE:** The Spindle of the converter is specific to the bottom arm selected for each door. Spindle profiles are available for most Dorma and Rixson bottom arm hardware for center hung, offset pivot hung, and offset butt hung (hinged) doors. Bottom arms are NOT supplied with the converter. Be certain that the Spindle ordered matches the bottom arm selected. See Opcon website for details.
- 3) **CEMENT CASE SIZE:** All cement cases are supplied at the standard size of 35-1/2" long X 7" wide. On pairs of doors, a conduit connects the cement cases and the width is variable. Pairs of doors narrower than 72" are available as a custom order. Contact Opcon for custom size details.
- 4) **FLOOR & PREPARATION:** The typical floor depth for the converter is 7" minimum. Center hung door excavation is the width between the jambs. Offset hung door excavation is the width between the jambs + 2" under the pivot side jambs.
- 5) **THRESHOLD & FLOORING:** Most thresholds must be 10" wide to cover the converter and excavation. Terrazzo/stone pans have a variable size between 8" and 10". Thresholds made to Opcon specifications are available directly from National Guard Products. Terrazzo & Stone Pans are also available for stone flooring directly from Opcon. Refer to Thresholds at website.
- 6) **ELECTRICAL & LOW VOLTAGE:** The electrical supply and low voltage signal lines must enter the cement case at the non-pivot side of the converter on single doors, and at or near the center on pairs of doors. Liquid Tight conduit fittings must be installed. Wireless activation requires sealed antennae placement through the cement case. Refer to Wiring section of the Install Manual.

PTN.	DESCRIPTION
1A	CEMENT CASE
1B	SPINDLE SEAL
1C	CEMENT CASE COVER
1D	PERIMETER GASKET
1E	CASE COUPLER F/PAIRS
1F	COUPLER COVER F/SINGLES
1G	CONDUIT CONNECTOR
2A	SLED BASE
2B	MOTOR MOUNT BRACKET (2)
2C-T	FRONT PIVOT HOUSING RISER
2D-T	REAR PIVOT HOUSING RISER
2E	BASE PLATE
2F/G	TOP PLATE/LAT BUSHING
2H	LOWER TENSIONER STOP
2J	BASE PLATE BOLT (2)
2K	LATERAL WEDGES (4)
2L	LATERAL HEX WEDGE
2M	UPPER CHAIN TENSIONER
2N	WEDGE & HANDING BRACKET
3A	PIVOT ARM SPINDLE
3B	SPINDLE SPROCKET
3C	SHAFT KEY
3D-1	STD. ANTI-SLIP COLLAR F/KEY
3D-2	ALT. ANTI-SLIP COLLAR F/KEY
3E	"O" -RING
3F	BEARING COVER
3G	TAPERED BEARING
3K	THRESHOLD SEAL
3L	"O" -RING SEAL
3M	RETAINING RING
4A	DRIVE SPROCKET
4B	THRUST WASHER
4C	NEEDLE BEARING
4D	THRUST WASHER
4E	FLAT WASHER
4F	LOCK WASHER
4G	HEX BOLT
5	DRIVE CHAIN OR BELT
6	THRESHOLD ASSY.
7	OPERATOR ASSY.

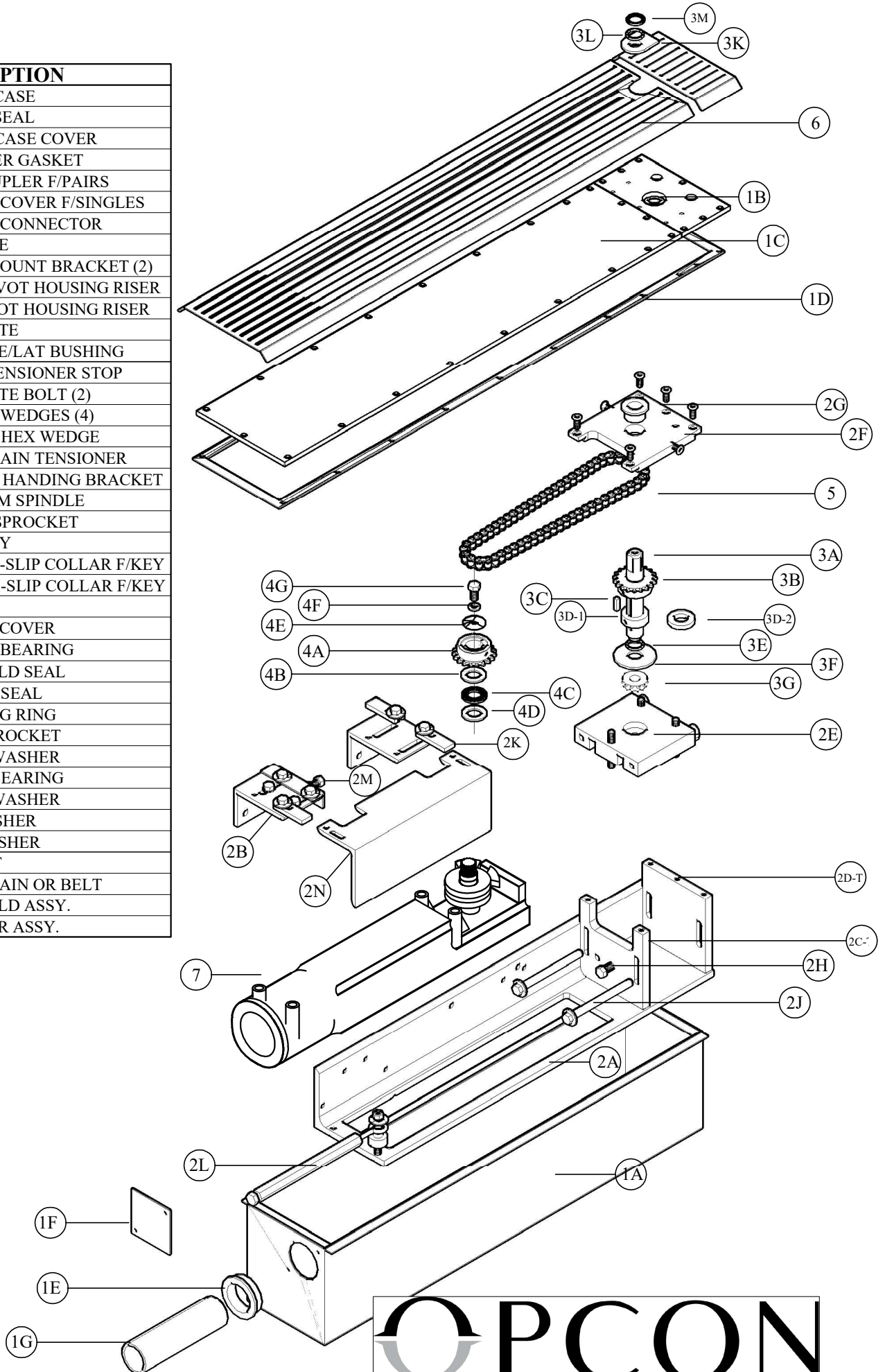

STANLEY MAGIC FORCE

© 2016 OpconUSA ALL RIGHTS RESERVED

OPCON
 . CONVERT . CONCEAL . CONNECT

OPCON

CONVERT CONCEAL CONNECT
OPERATOR ASSEMBLY

(PROCEDURE 1)
STANLEY MAGIC FORCE

STEP 3: Place sled over operator & attach with 4 hex bolts. Then slide operator forward on sled

STEP 2: Remove angle wedge
STEP 4: Replace angle wedge

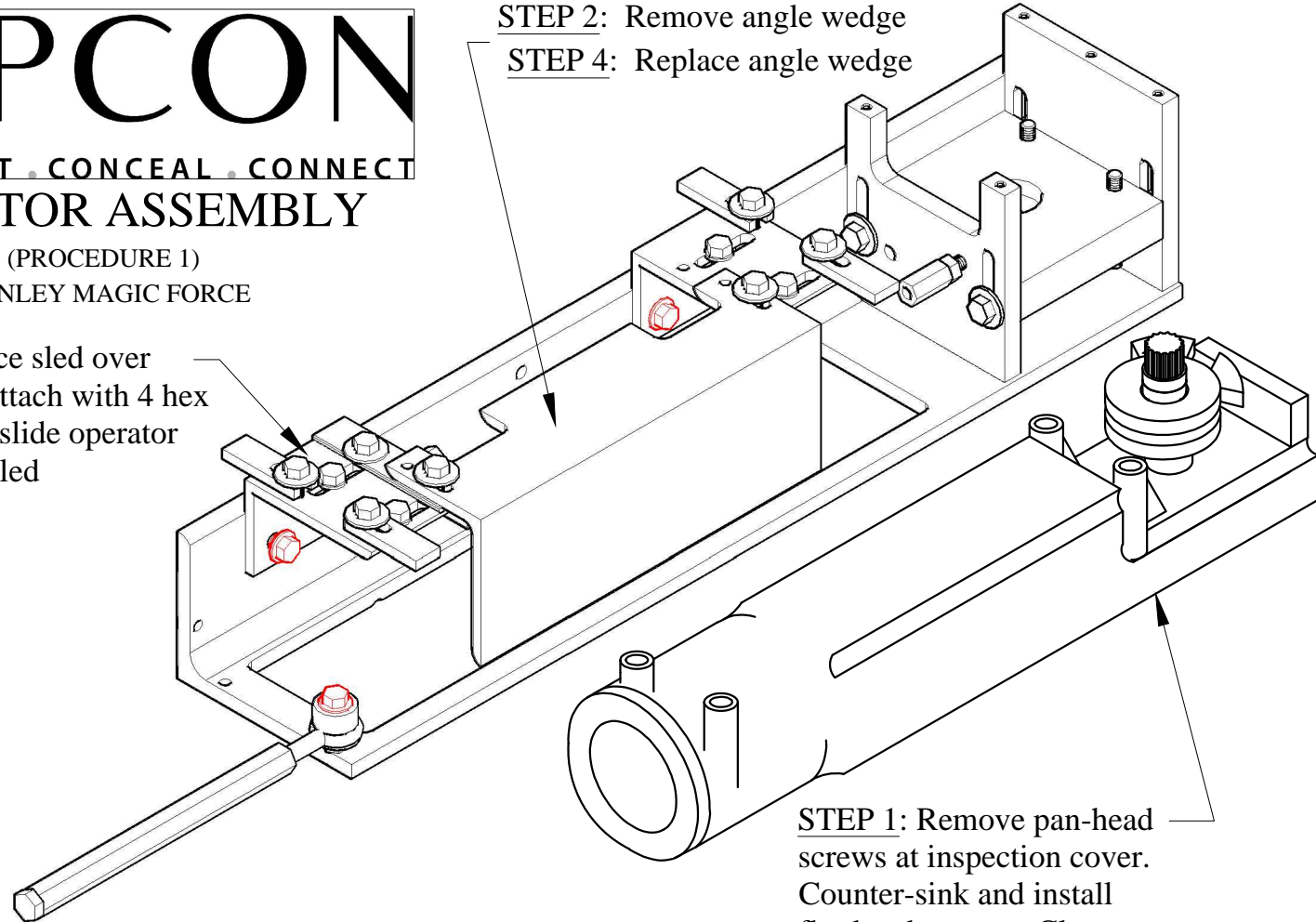

STEP 1: Remove pan-head screws at inspection cover. Counter-sink and install flat-head screws. Clearance required for spindle seals.

NOTES/PROCEDURE:

1. Reference isometric drawing for more details.
2. Right hand outswing shown; uses left hand outswing operator due to upside-down mounting. Program for left-hand outswing.
3. After mounting, power operator to 90° open position & set open stop block location.
4. See chain and sprocket assembly to continue.

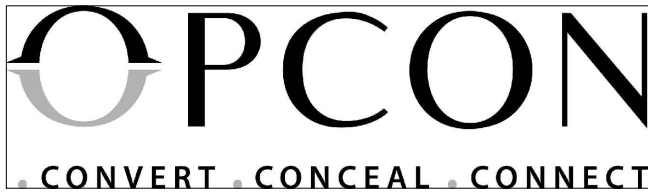

CHAIN AND SPROCKET ASSEMBLY

(PROCEDURE 2)
STANLEY MAGIC FORCE

STEP 3: Install chain over gearbox sprocket; index spindle to full open position; tilt spindle to place chain over sprocket.

STEP 4: Re-install top plate.

STEP 1: Remove top plate & install drive spindle parts sequenced as shown.

*ASSEMBLE CHAIN WITH ALL FURNISHED LINKS (CONNECTING & OFFSET).

*ALT SPINDLE COLLAR (1/4") USE WHEN SPINDLE MUST BE RAISED HIGHER THAN 9/16" SPINDLE COLLAR PERMITS.

STEP 2: Install gearbox sprocket/hub assy sequenced as shown. Power unit open to full 90° position.

NOTES/PROCEDURE:

1. From procedure #1, operator is mounted to sled and powered to 90° open position before installing chain and sprockets.
2. After chain and sprocket assembly, slide operator away from spindle to tension chain (see procedure 3).

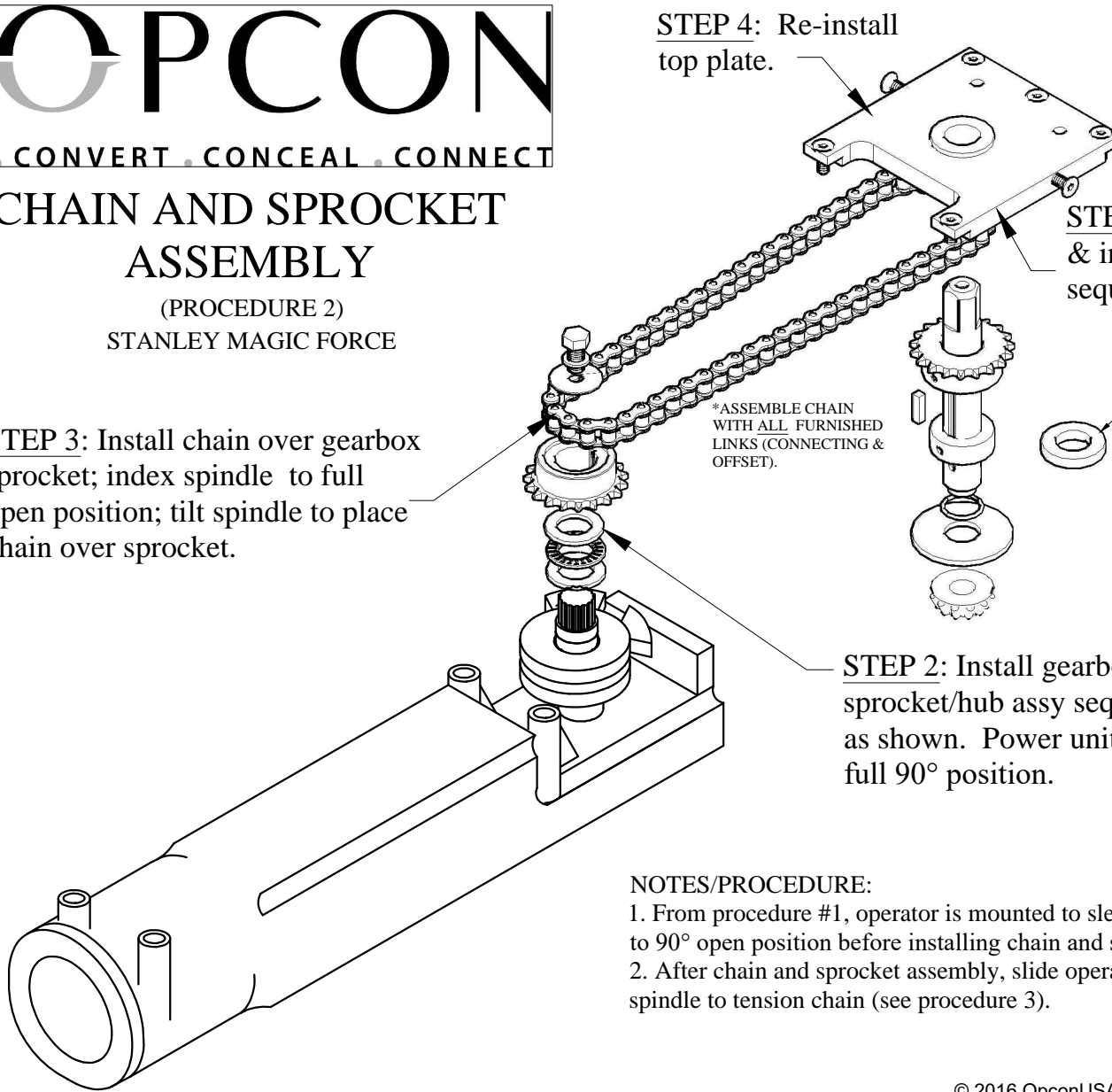



CHAIN TENSION & TUNE

(PROCEDURE 3)
STANLEY MAGIC FORCE

STEP 2: Adjust top chain tensioner to $\frac{3}{8}$ " slack in chain. Then tighten 4 mounting bolts. Be sure that 1/2-round block is between operator mounts.

STEP 3: Adjust stop blocks for open & closing positions. Pre-load closing position to assure pressure against stop. Attach temporary power & tune to specs.

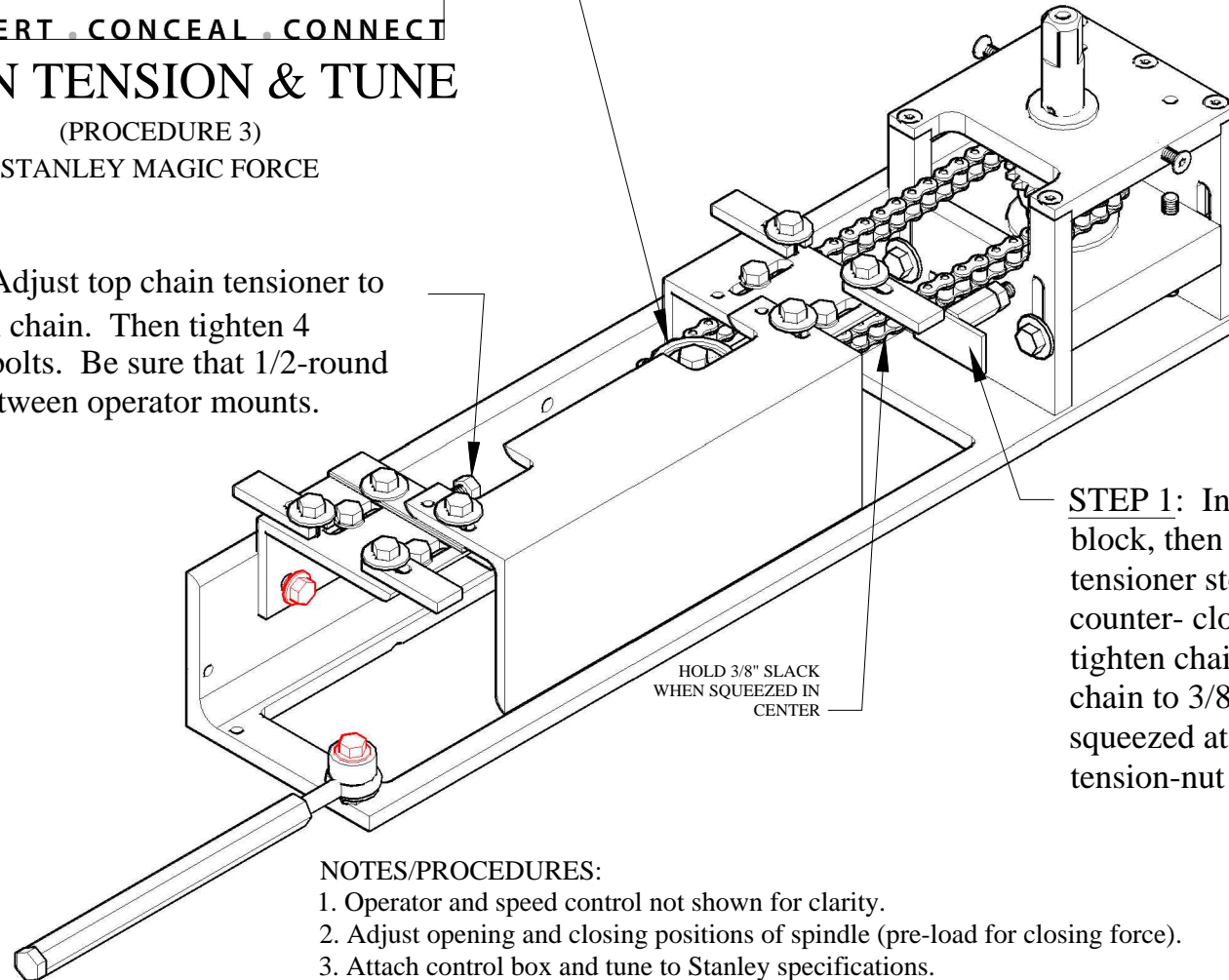

STEP 1: Insert rubber block, then turn chain tensioner stop-block counter-clockwise to tighten chain.. Adjust chain to $\frac{3}{8}$ " slack when squeezed at center. Lock tension-nut with jam-nut.

NOTES/PROCEDURES:

1. Operator and speed control not shown for clarity.
2. Adjust opening and closing positions of spindle (pre-load for closing force).
3. Attach control box and tune to Stanley specifications.
4. Install completed and tuned assembly into cement case.



SPINDLE CENTERING & WEDGING

(PROCEDURE 4)
STANLEY MAGIC FORCE

STEP 1: Center spindle using 2 bolts on top plate. Minimize pressure on cement case to avoid misalignment of cover screws.

STEP 2: Adjust hex bar for lateral movement. Insert shims behind spindle housing for alternate spindle locating.

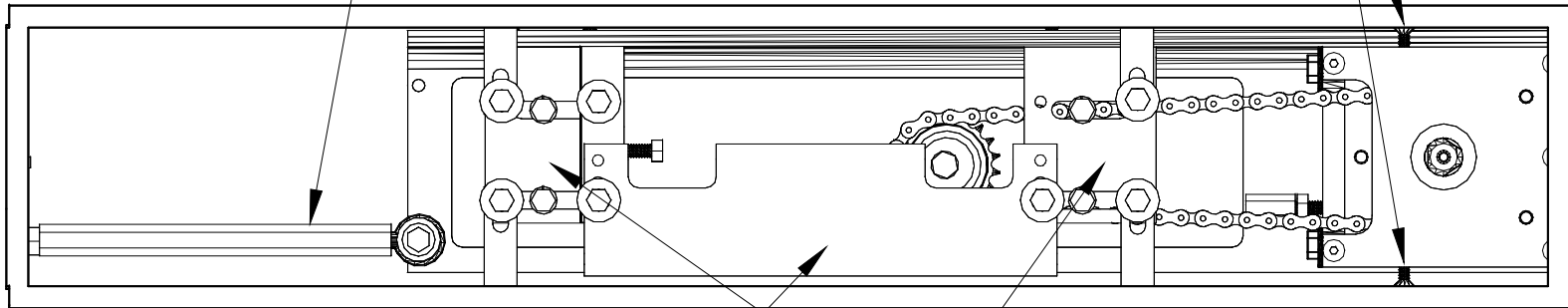

ANGLE WEDGE

STEP 3: Tighten horseshoe wedges at 4 places and angle wedge at 2 places. Wedge flat and tight against cement case and tighten 2 set screws and nuts.

NOTES/PROCEDURES:

1. Operator and speed control not shown for clarity.
2. Insert tuned converter/operator assembly into cement case.
3. Adjust spindle to center of cement case using adjusting bolts and hex bar.
4. Wedge sled assembly firmly within cement case.



SPINDLE HEIGHT ADJUSTMENT

(PROCEDURE 5)
STANLEY MAGIC FORCE

STEP 1: Loosen (2) 9/16" base
plate bolts. Do not remove.

STEP 3: Re-tighten (2) 9/16"
base plate bolts.

Spindle
shoulder

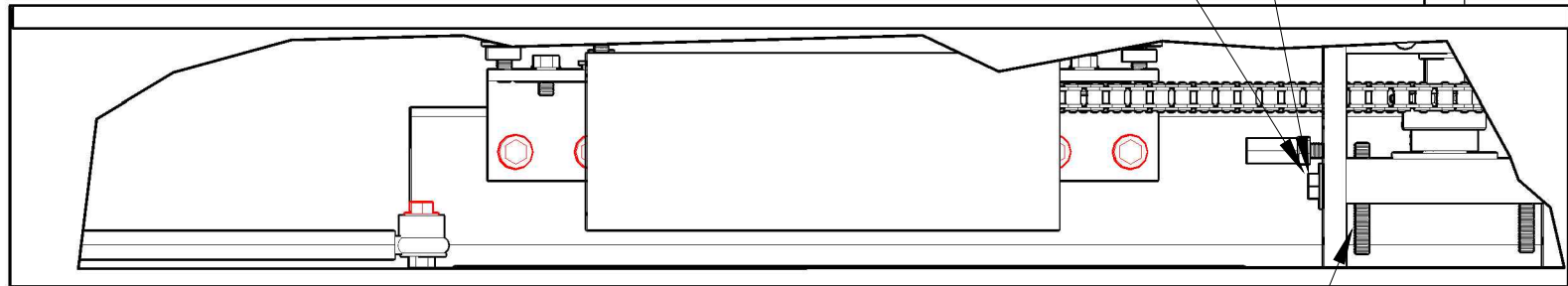

STEP 2: Adjust base-plate height using
Allen wrench on 3 threaded posts. Turn
clockwise to raise; turn counter-clockwise
to lower. Turn each post equally.

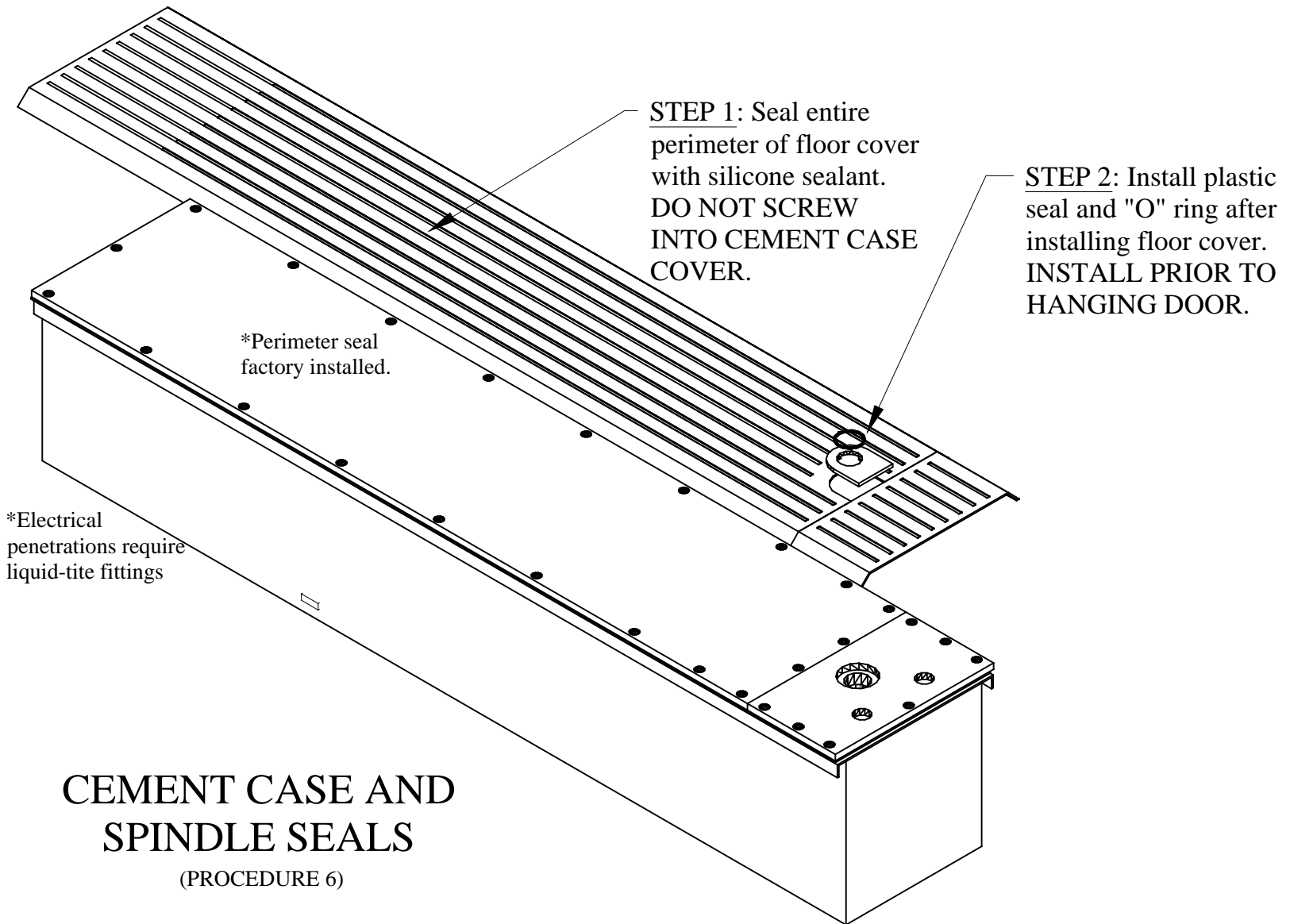

CEMENT CASE AND SPINDLE SEALS

(PROCEDURE 6)



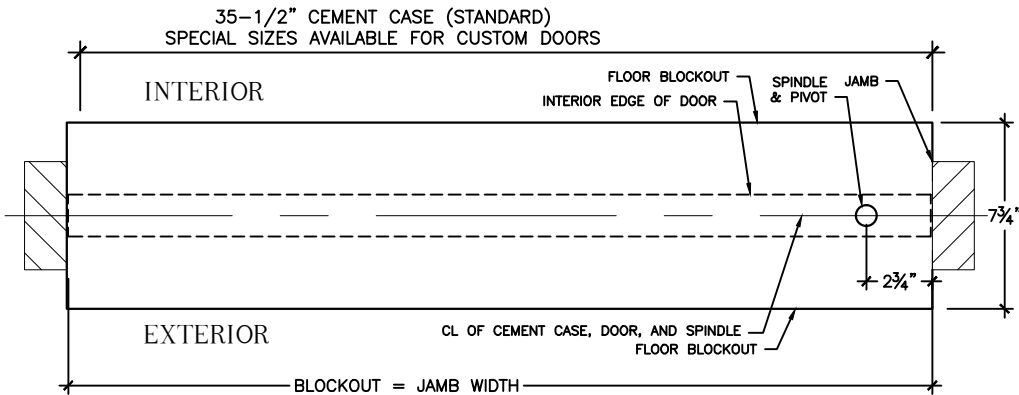

OPCON
 . CONVERT . CONCEAL . CONNECT
FIELD LAYOUT TEMPLATE
 FLOOR BLOCKOUT
 CENTER HUNG DOORS

**SINGLE DOOR : LEFT HAND OUTSWING (RHR) SHOWN
 RIGHT HAND OUTSWING (LHR) OPPOSITE**

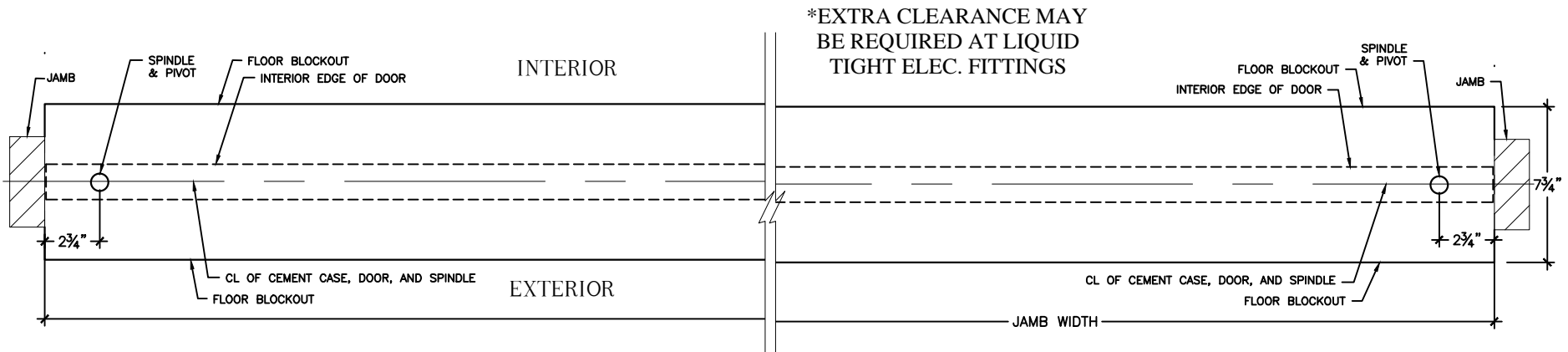

OUTSWING DOOR PAIR

NOTES

1. CENTER HUNG DOORS ONLY. DIMENSIONS DIFFERENT ON OFFSET PIVOT AND BUTT HUNG DOORS
2. SEE MANUFACTURERS TEMPLATE FOR LATEST DOOR LEAF AND BOTTOM ARM PREP
3. DEPTH OF EXCAVATION IS 7" MINIMUM BELOW FINISHED FLOOR
4. SPINDLE CENTER MUST BE PLUMB WITH TOP PIVOT

FL-C101

© 2016 OpconUSA ALL RIGHTS RESERVED

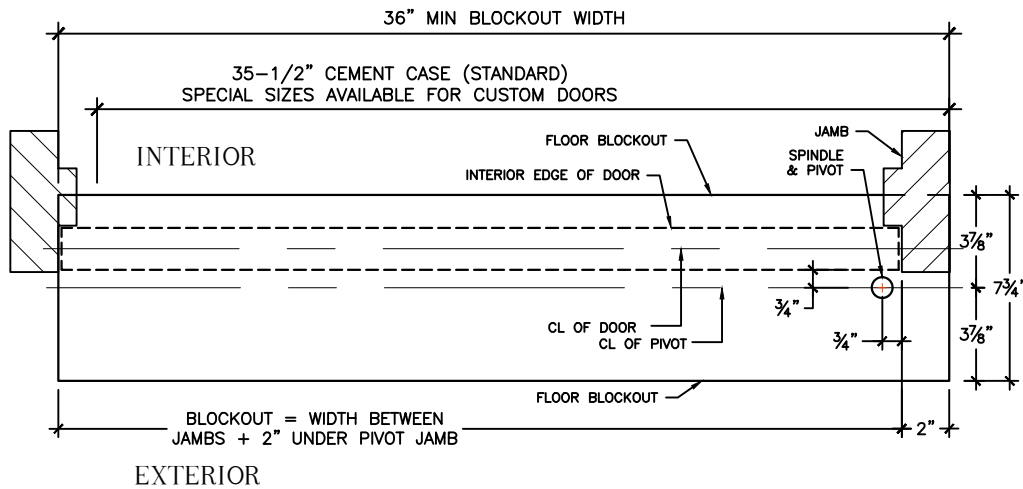

SINGLE DOOR : LEFT HAND OUTSWING (RHR) SHOWN
 RIGHT HAND OUTSWING (LHR) OPPOSITE



FIELD LAYOUT TEMPLATE

FLOOR BLOCKOUT WITH STANDARD
 BOTTOM ARMS ONLY

(RIXSON #27 OR DORMA BTS-80, ETC.)

3/4" OFFSET PIVOT HUNG DOORS ONLY

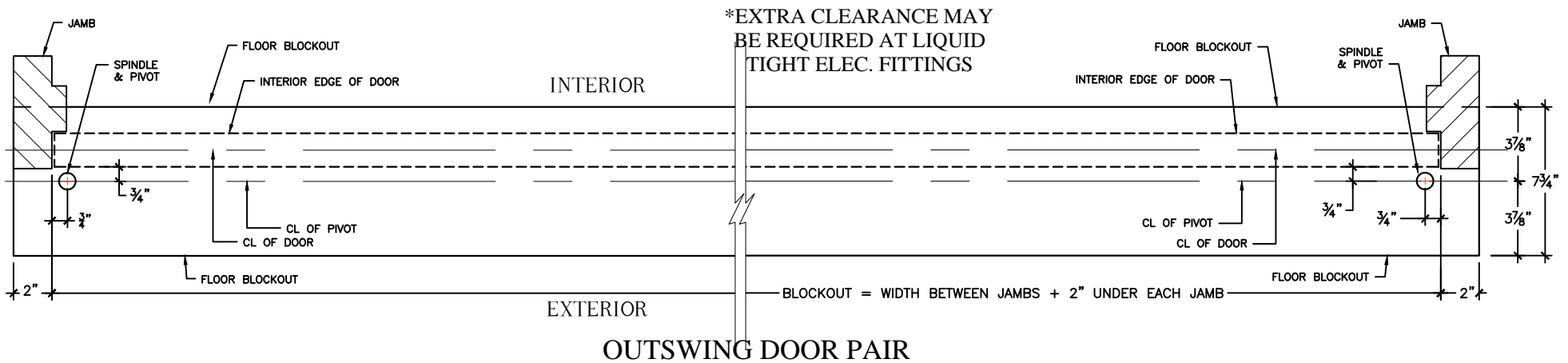

NOTES

1. 3/4" OFFSET PIVOT DOORS USING STANDARD BOTTOM ARMS ONLY. DIMENSIONS DIFFERENT ON BUTT HUNG (HINGED), OFFSET SLIDE-ARM, AND CENTER-HUNG DOORS
2. SPINDLE MUST BE PLUMB WITH PIVOT CENTER. SEE MANUFACTURER'S CURRENT TEMPLATE FOR BOTTOM ARM PLACEMENT ON DOOR
3. DEPTH OF EXCAVATION IS 7" MINIMUM BELOW FINISHED FLOOR

FL-P101-S27

© 2016 OpconUSA ALL RIGHTS RESERVED

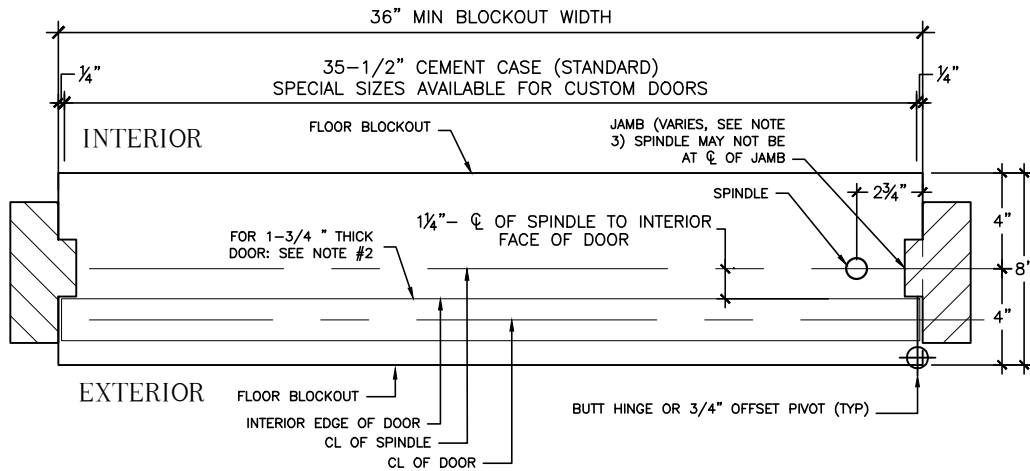

**SINGLE DOOR : LEFT HAND OUTSWING (RHR) SHOWN
RIGHT HAND OUTSWING (LHR) OPPOSITE**



CONVERT . CONCEAL . CONNECT
FIELD LAYOUT TEMPLATE
FLOOR BLOCKOUT FOR
BUTT HUNG (HINGED) AND 3/4" OFFSET PIVOT DOORS

USING DORMA BTS-81 BOTTOM ARM & 7451N SLIDE TRACK

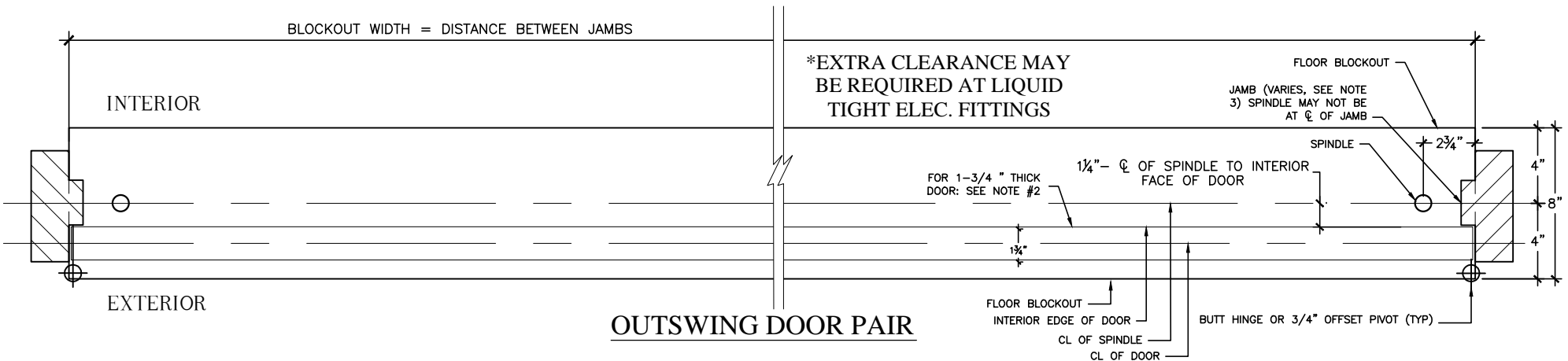

NOTES

1. BUTT HUNG (HINGED) & 3/4" OFFSET PIVOT DOORS USING DORMA BOTTOM ARM AND SLIDE TRACK
2. DIMENSIONS ARE FOR 1-3/4" DOOR THICKNESS. HOLD 1-1/4" DIMENSION FROM INSIDE FACE OF ANY DOOR THICKNESS TO CENTERLINE OF SPINDLE. SPINDLE MAY NOT BE AT CENTERLINE OF JAMB.
3. JAMB WIDTHS VARY. PLACEMENT DIMENSIONS ARE FROM INTERIOR FACE OF JAMB TO CENTER OF SPINDLE.
4. DEPTH OF EXCAVATION IS 7" MINIMUM BELOW FINISHED FLOOR

INSTALLATION PROCEDURE

ALL MANUFACTURERS - ALL STANDARD OPERATORS

CENTER HUNG DOORS

2 ³/₄" Pivot Setback (Rixson #28, Dorma BTS-80, etc.)

1. Cut concrete or floor to dimensions detailed on blockout/template drawing. Blockout must be entire door width between jambs.
2. Layout & drill cement case for electrical & signal lines
3. Install electric & low voltage conduit with liquid-tite fittings.
4. Install top door pivot & locate center of OPCON converter spindle using a plumb-bob/laser.
5. Cement case must be parallel with door header.
6. For PAIRS of doors the cases will be set separately with a connecting conduit at center.
7. Cement case must be level & plumb in all directions.
8. Set cement case into excavation & secure in position.
9. Pourstone ONLY around bottom 1" of cement case. **INSTALL SPINDLE/SHAFT SEALS NOW.** Hang door and final adjust position.
10. Final pourstone cement case with OPCON converter assembly & door leaf in place.

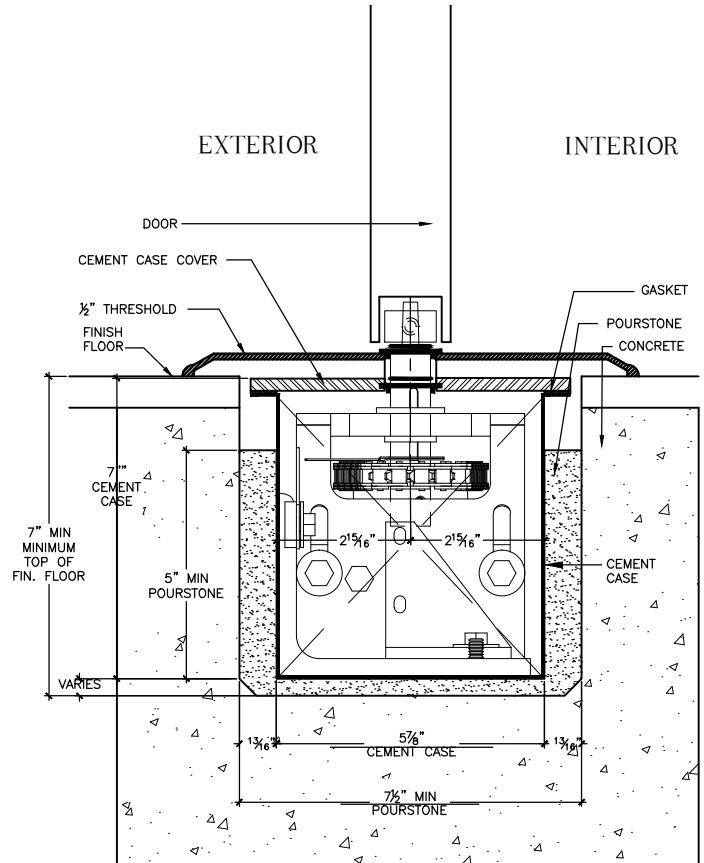
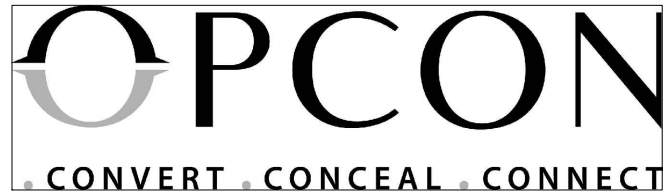

NOT TO SCALE

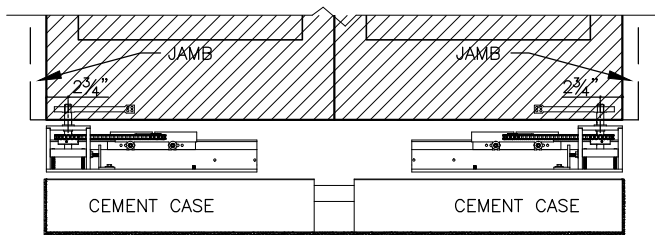

(CEMENT CASES SHOWN BELOW CONVERTER)
CENTER HUNG DOORS - PAIR

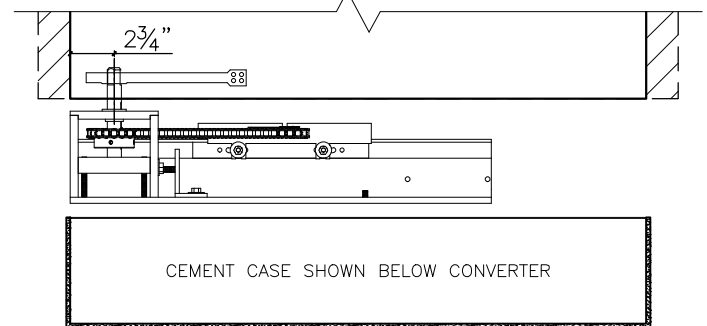
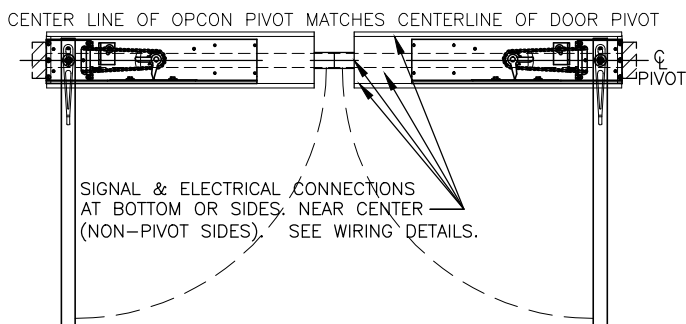

CENTER HUNG DOOR - SINGLE

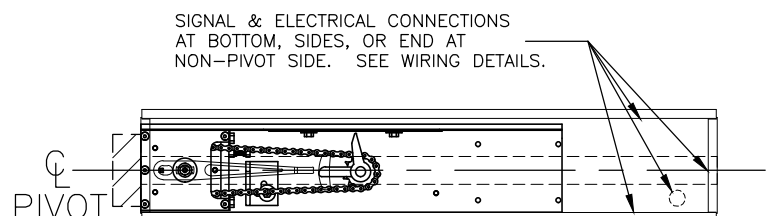

INSTALLATION PROCEDURE

ALL MANUFACTURERS - ALL STANDARD OPERATORS

OFFSET (PIVOT) HUNG DOORS

3/4" Pivot Setback (Rixson #27, Dorma BTS-80, etc.)

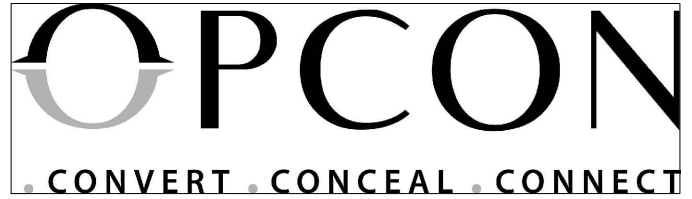

1. Cut concrete or floor to dimensions detailed on blockout/template drawing. Blockout must be entire door width between jambs + 2" under each pivot jamb.
2. Layout & drill cement case for electrical & signal lines
3. Install electric & low voltage conduit with liquid-tite fittings.
4. Install top door pivot & locate center of OPCON converter converter spindle using a plumb-bob/laser.
5. Cement case must be parallel with door header.
6. For PAIRS of doors the cases will be set separately with a connecting conduit at center.
7. Cement case must be level & plumb in all directions.
8. Set cement case into excavation & secure in position.
9. Pourstone ONLY around bottom 1" of cement case.
Hang door and final adjust position.
10. Final pourstone cement case with OPCON converter assembly & door leaf in place.

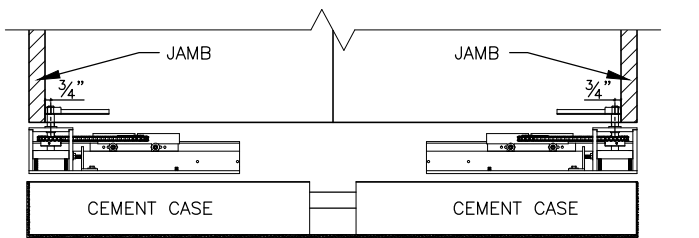
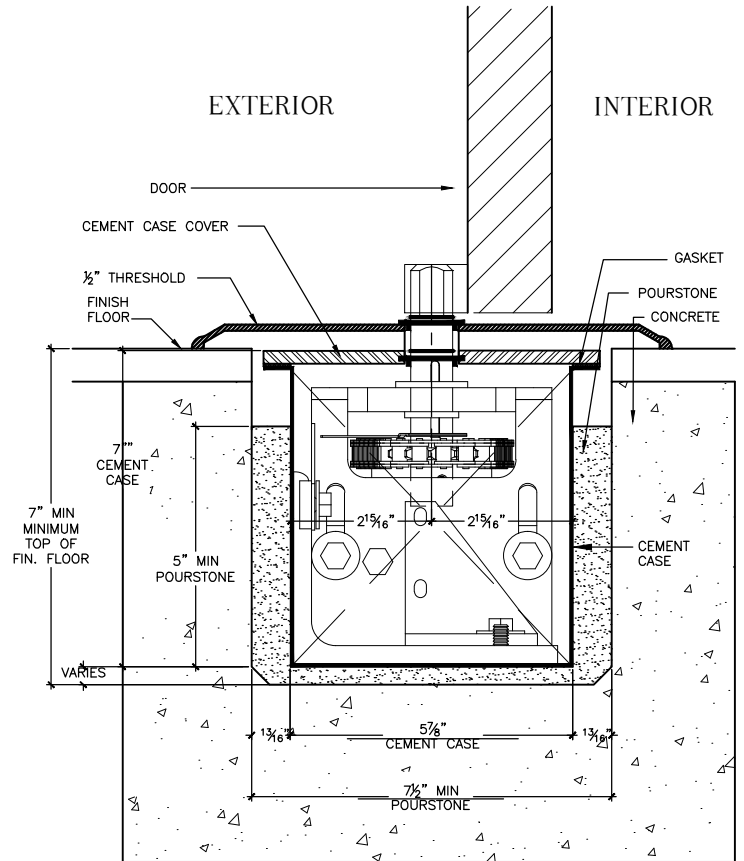

CONNECTING CONDUIT
(CEMENT CASES SHOWN BELOW CONVERTER)
OFFSET HUNG DOORS - PAIR
CENTER LINE OF OPCON PIVOT MATCHES CENTERLINE OF DOOR PIVOT

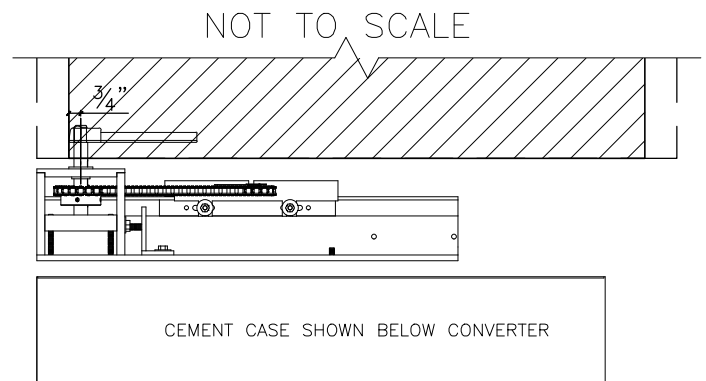
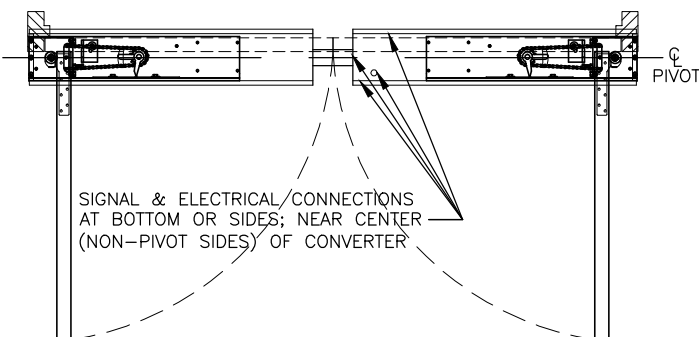

OFFSET HUNG DOOR - SINGLE

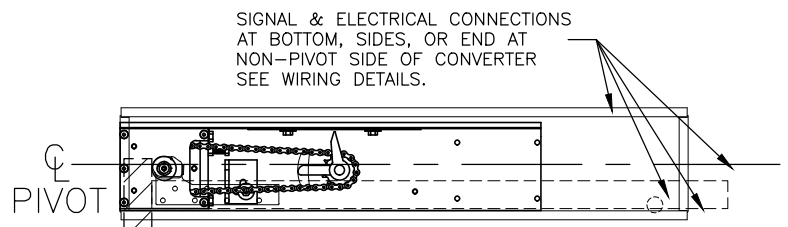

INSTALLATION PROCEDURE

ALL MANUFACTURERS - ALL STANDARD OPERATORS

BUTT-HUNG (HINGED) DOORS

Hinged Setback (Dorma #7451N Slide-arm or Rixson #327)



1. Cut concrete or floor to dimensions detailed on blockout/template drawing. Blockout must be entire door width between jambs.
2. Layout & drill cement case for electrical & signal lines
3. Install electric & low voltage conduit with liquid-tite fittings.
4. Establish location of exterior door face & locate center of OPCON converter spindle. **DRAWING ASSUMES 1-3/4" THICK DOOR, ADJUST DIMENSIONS FOR THICKER OR THINNER DOORS.**
5. Cement case must be parallel with door header.
6. For PAIRS of doors the cases will be set separately with a connecting conduit at center.
7. Cement case must be level & plumb in all directions.
8. Set cement case into excavation & secure in position.
9. Pourstone ONLY around bottom 1" of cement case.
Hang door and final adjust position.
10. Final pourstone cement case with OPCON converter assembly & door leaf in place.

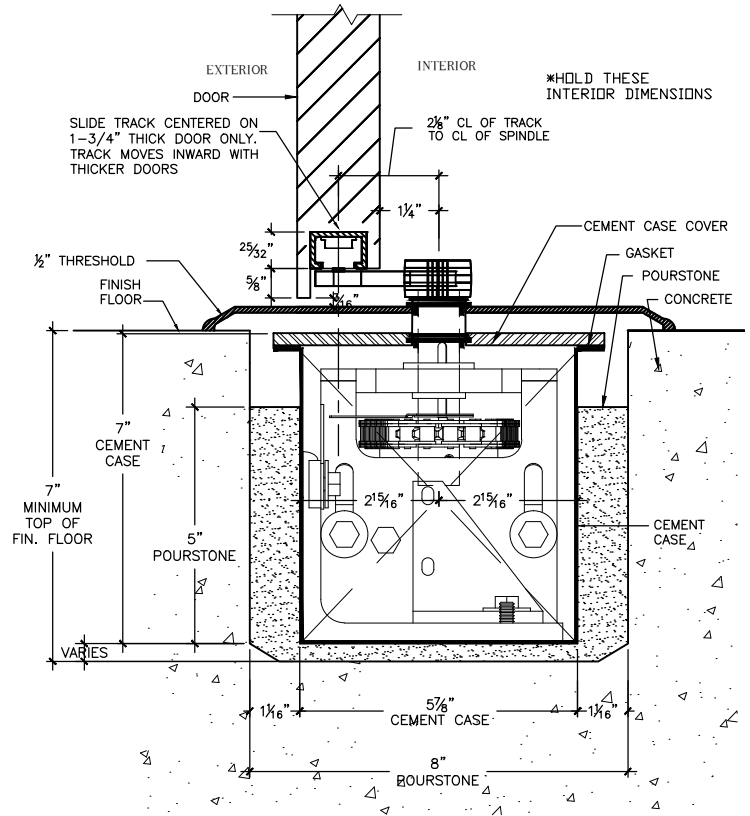

NOT TO SCALE

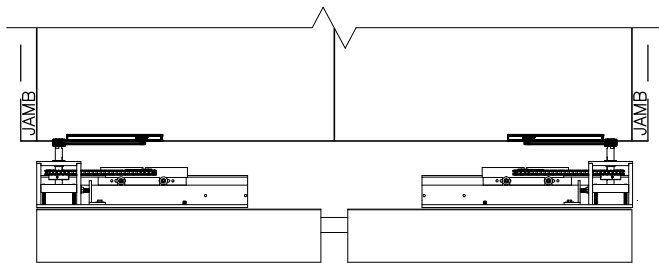

(CEMENT CASES SHOWN BELOW CONVERTER)
OFFSET HUNG DOORS - PAIR

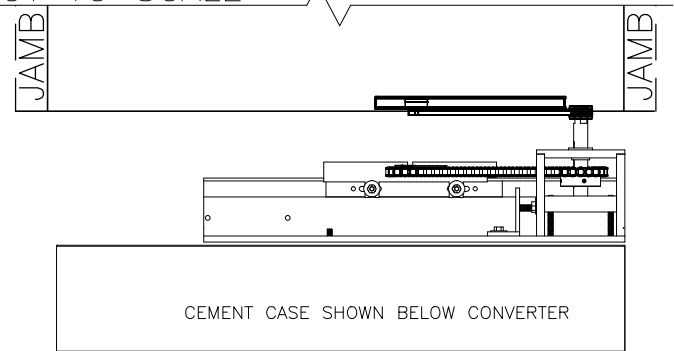
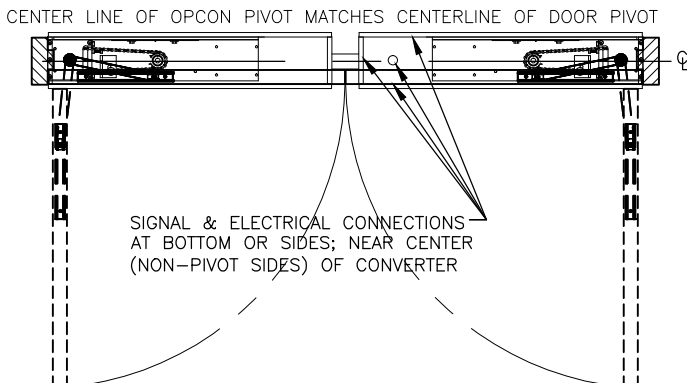

OFFSET HUNG DOOR - SINGLE

SIGNAL & ELECTRICAL CONNECTIONS AT BOTTOM, SIDES, OR END AT NON-PIVOT SIDE OF CONVERTER SEE WIRING DETAILS.

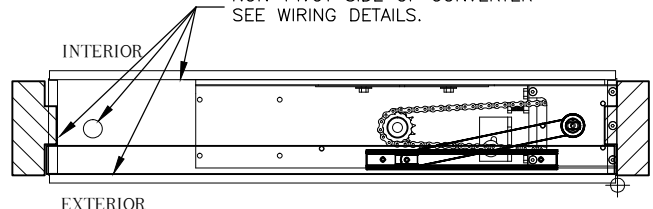

CONDUIT CONNECTIONS

ELECTRIC & LOW VOLTAGE LINES

TYPICAL FOR ALL INSTALLATIONS
(Standard System for Single and Dual Cement Cases)

1. Verify power requirements with operator manufacturer & layout cement case for conduit.
2. Verify low voltage signal lines for accessories & layout cement case for conduit.
3. Conduit to cement case connection MUST be OPCON supplied "liquid-tight" water tight fittings specifying Arlington #LT7. Field drilled as required by supplied drawing detail. Conduit & liquid-tight fittings required for both 120VAC and low voltage signal runs.
4. Conduit connections to convertor must be at the strike side of single doors and near center of dual doors as shown. Holes may be located at sides, bottom, or end (on single doors) of cement case. MUST be liquid-tight fittings (Arlington #LT7). Use of other fittings may cause leaks & void warranty.



SINGLE CASES

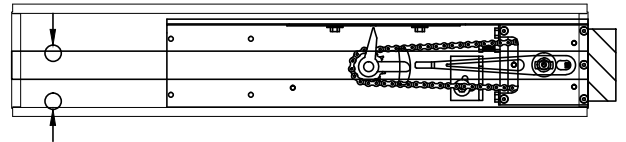
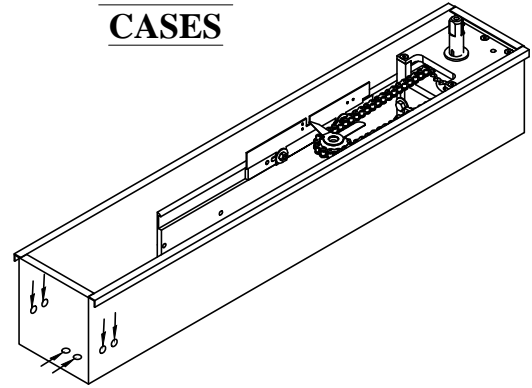

DUAL CASES

Power required to one case only

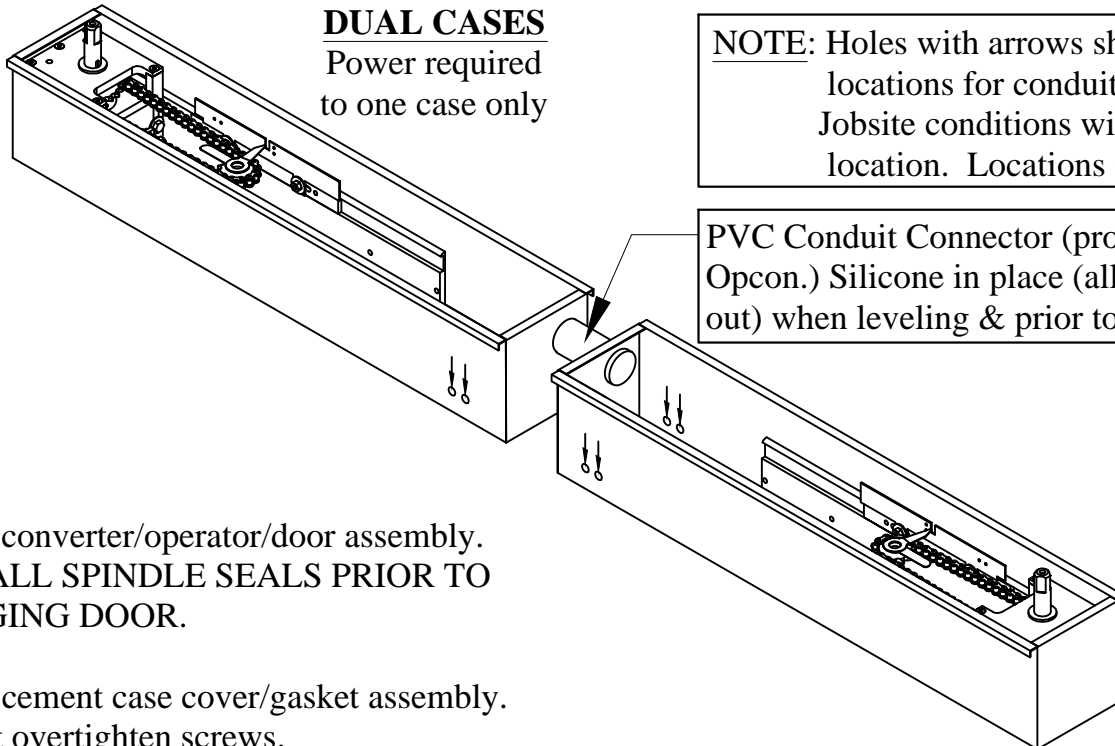

NOTE: Holes with arrows show the best locations for conduit penetrations. Jobsite conditions will dictate actual location. Locations vary by operator.

PVC Conduit Connector (provided by Opcon.) Silicone in place (all sides-inside & out) when leveling & prior to pourstone.

5. Install converter/operator/door assembly. **INSTALL SPINDLE SEALS PRIOR TO HANGING DOOR.**
6. Install cement case cover/gasket assembly. Do not overtighten screws.

EXTERIOR

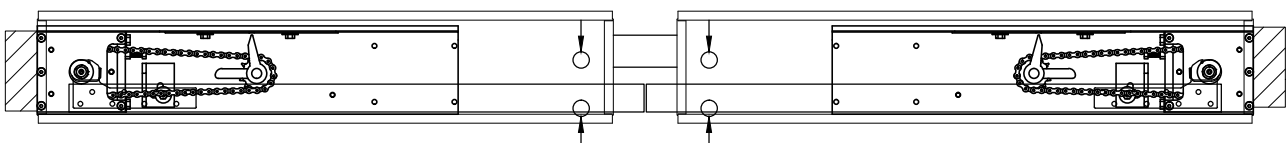

SIMPLY PUSH LIQUID-TIGHT CONDUIT OVER FERRULE END OF FITTING. WHILE PUSHING CONNECTOR, TURN CONDUIT SLIGHTLY CLOCKWISE TO SEAT IT.

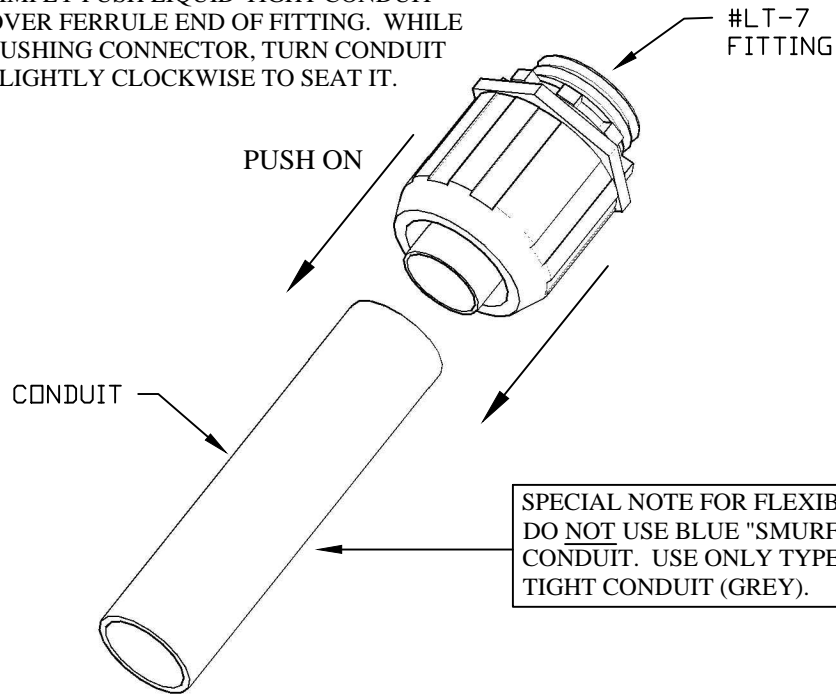

SPECIAL NOTE FOR FLEXIBLE CONDUIT: DO NOT USE BLUE "SMURF" FLEXIBLE CONDUIT. USE ONLY TYPE "B" SEAL TIGHT CONDUIT (GREY).

BORE CEMENT CASE 1-1/16" MIN. TO 1-1/8" MAX. TO ACCEPT LIQUID TIGHT FITTING. SEE OPCON PENETRATION DRAWING FOR ACCEPTABLE BORE LOCATIONS.

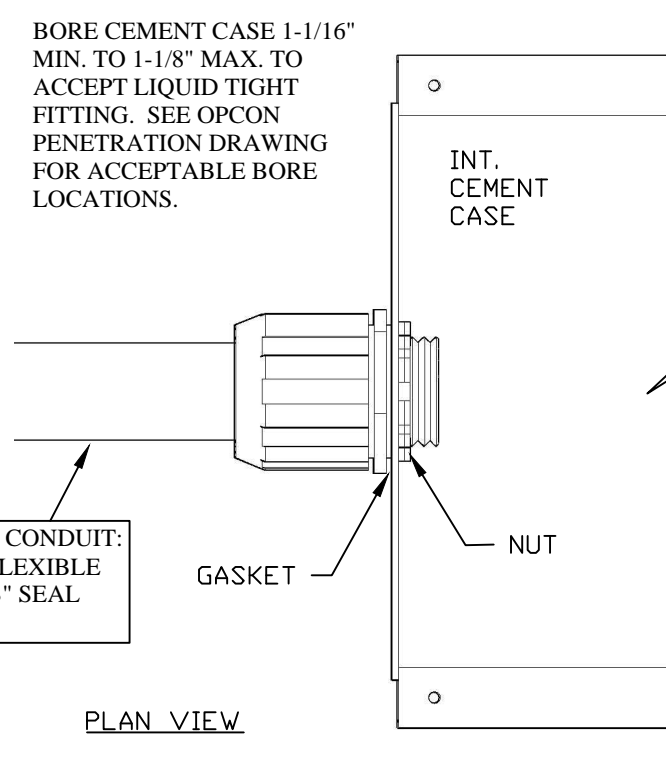

ARLINGTON #LT-7 LIQUID-TIGHT FITTING MUST BE USED FOR ELECTRICAL AND LOW VOLTAGE PENETRATIONS ON CEMENT CASE. OTHER FITTINGS HAVE NOT BEEN TESTED OR APPROVED; AND MAY CAUSE LEAKS THAT MAY VOID WARRANTY.



WIRING REQUIREMENTS STANDARD INSTALL



ALL WIRING TO NON-PIVOT SIDE OF DOOR LEAF. WIRES TO CENTER ON PAIRS; WIRES TO STRIKE SIDE ON SINGLES. SEE ELECTRICAL PENETRATION DRAWING IN MANUAL FOR CONDUIT FITTING LOCATION ON CEMENT CASE. SEE OPERATOR MANUFACTURER'S MANUAL FOR SPECIFIC WIRING REQUIREMENTS

② REF SHOP DWG FOR SECTION

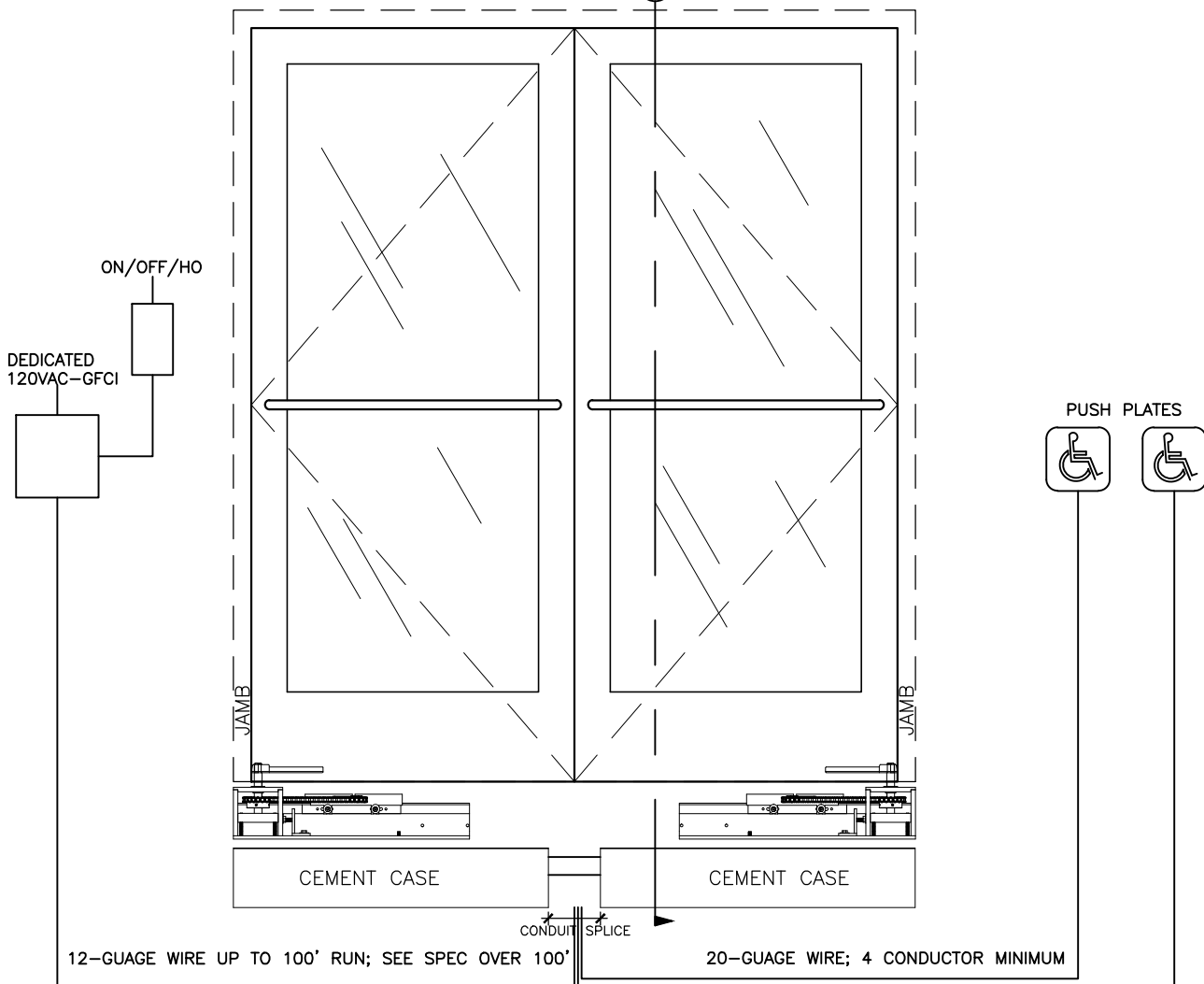

FRONT ELEVATION ③ SCALE = 1:20

CEMENT CASES SHOWN BELOW SLEDS FOR CLARITY
SINGLE DOOR WIRING SIMILAR-USE LIQUID TIGHT CONDUIT FITTINGS

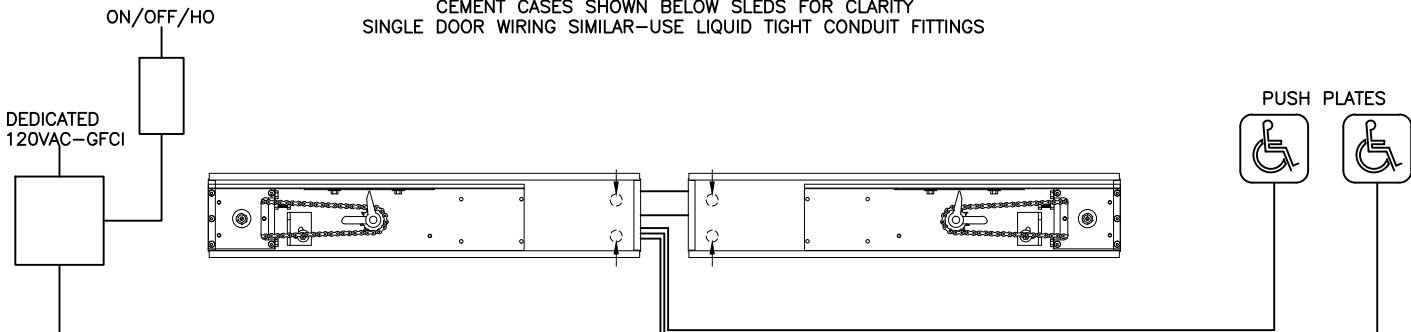

PLAN VIEW SCALE = 1:16

WIRING REQUIREMENTS ELECTRIC PANIC DEVICE INSTALLATION



ALL WIRING TO NON-PIVOT SIDE OF DOOR LEAF. WIRES TO CENTER ON PAIRS; WIRES TO STRIKE SIDE ON SINGLES. SEE ELECTRICAL PENETRATION DRAWING IN MANUAL FOR CONDUIT FITTING LOCATION ON CEMENT CASE. SEE OPERATOR/DEVICE MANUFACTURER'S MANUAL FOR SPECIFIC WIRING

② REF SHOP DWG FOR SECTION

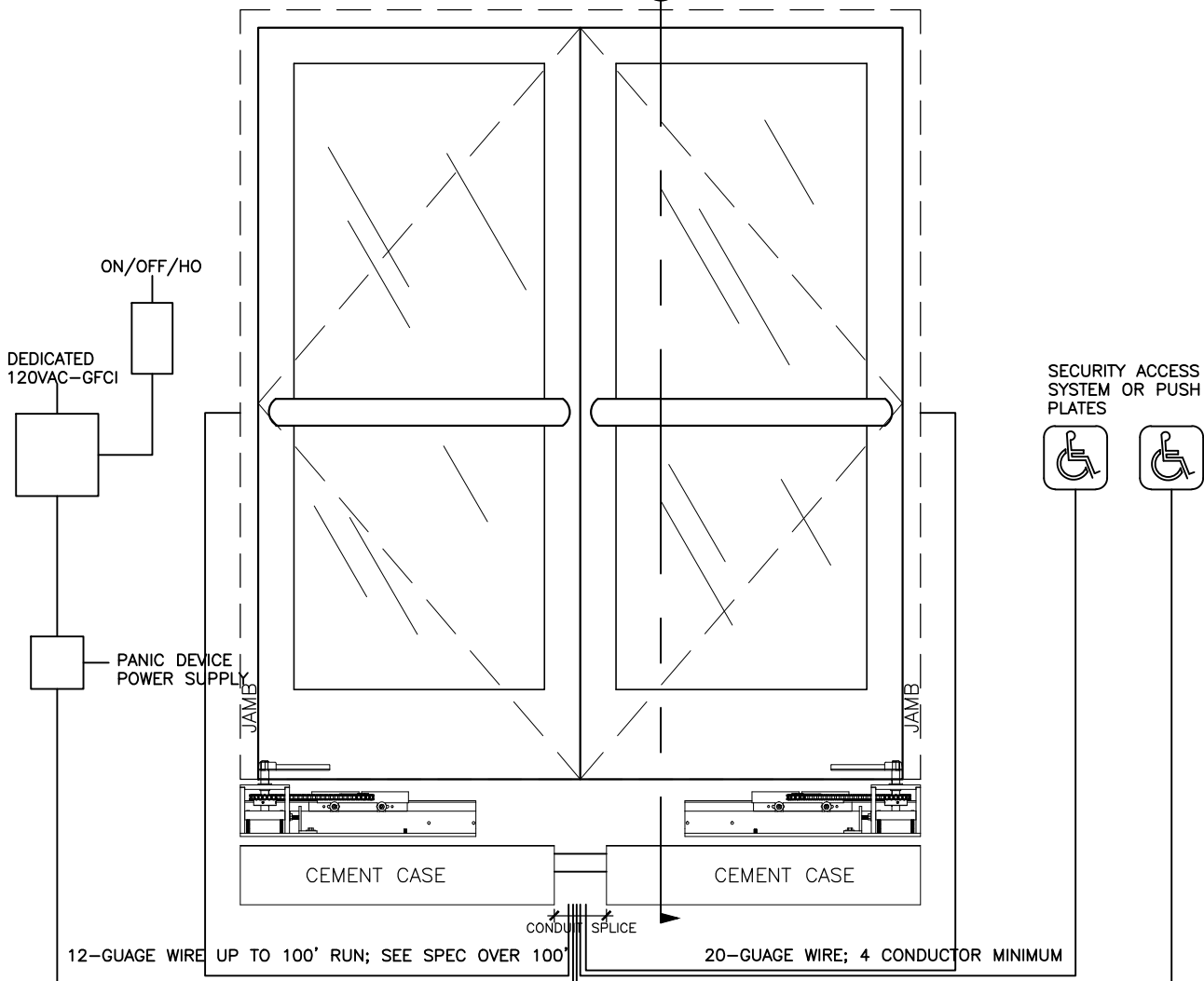

FRONT ELEVATION ③ SCALE = 1:20

CEMENT CASES SHOWN BELOW SLEDS FOR CLARITY
SINGLE DOOR WIRING SIMILAR-USE LIQUID TIGHT CONDUIT FITTINGS

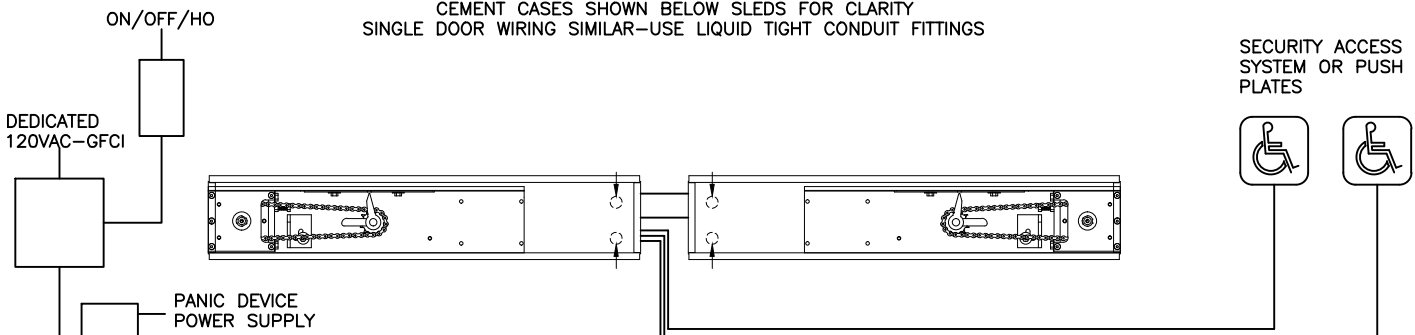

PLAN VIEW

SCALE = 1:16

WIRING REQUIREMENTS OVERHEAD LOCK INSTALL



ALL WIRING TO NON-PIVOT SIDE OF DOOR LEAF. WIRES TO CENTER ON PAIRS;
WIRES TO STRIKE SIDE ON SINGLES. SEE ELECTRICAL PENETRATION DRAWING IN
MANUAL FOR CONDUIT FITTING LOCATION ON CEMENT CASE. SEE LOCK &
OPERATOR MANUFACTURER'S MANUALS FOR SPECIFIC WIRING REQUIREMENTS

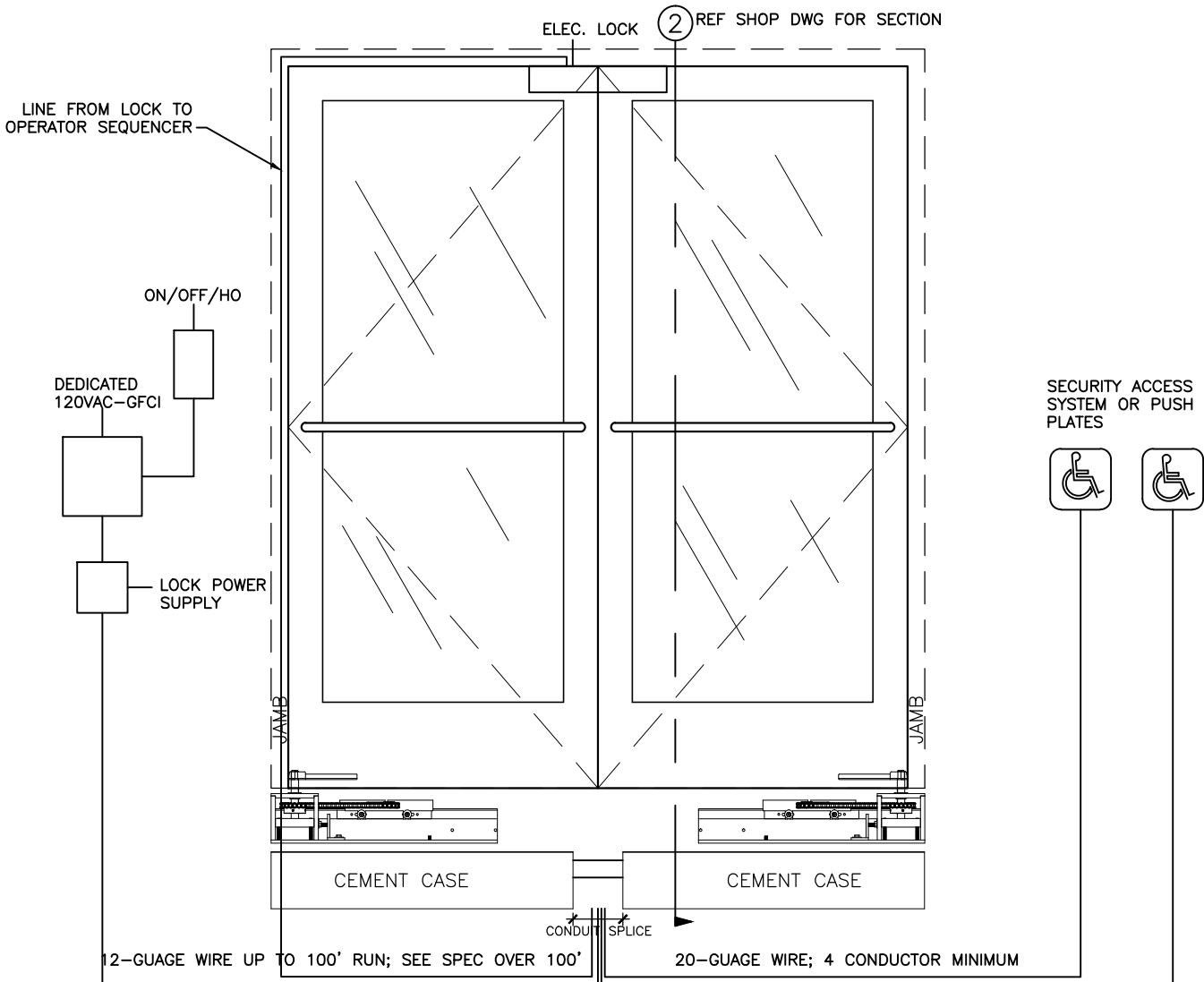

FRONT ELEVATION ③ SCALE = 1:20

CEMENT CASES SHOWN BELOW SLEDS FOR CLARITY
SINGLE DOOR WIRING SIMILAR—USE LIQUID TIGHT CONDUIT FITTINGS

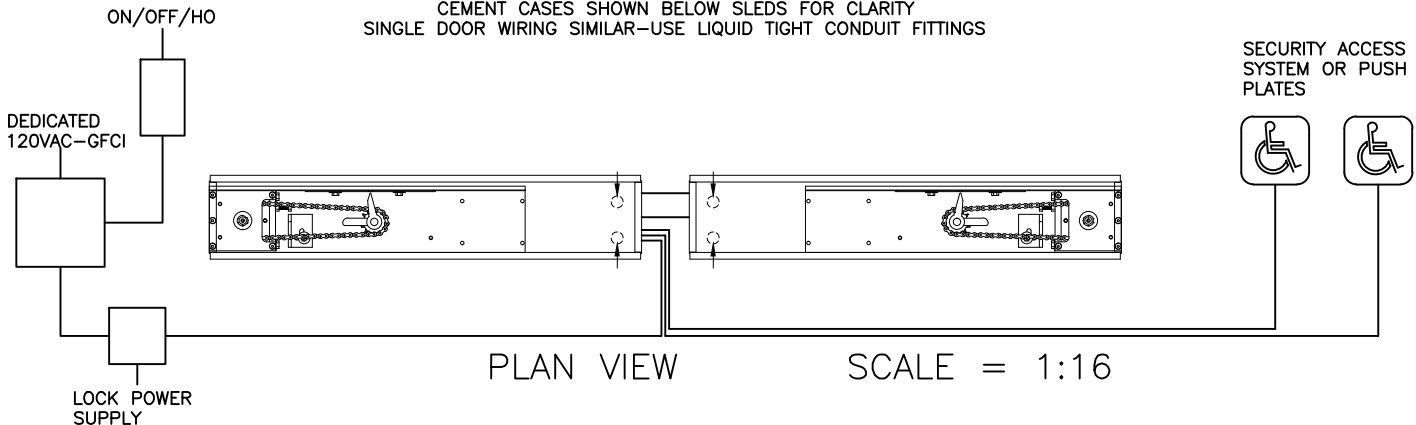

WIRING REQUIREMENTS BOTTOM LOCK INSTALL



BOTTOM RAIL LOCK DESIGN IS BASED ON LOCKNETICS SHEAR LOCK MODEL #GF3000BRD. OPCON REQUIRES A WATERTIGHT LOCK HOUSING AVAILABLE AS AN OPTION WITH ALL BOTTOM RAIL LOCK INSTALLATIONS. ALL WIRING TO NON-PIVOT SIDE OF DOOR LEAF. WIRES TO CENTER ON PAIRS; WIRES TO STRIKE SIDE ON SINGLES. SEE ELECTRICAL PENETRATION DRAWING IN MANUAL FOR CONDUIT FITTING LOCATION ON CEMENT CASE. SEE LOCK & OPERATOR MANUFACTURER'S MANUALS FOR SPECIFIC WIRING REQUIREMENTS

NOTE: REQUIRES IN-FIELD FABRICATION/MODIFICATION TO THRESHOLD & CEMENT CASE. ADEQUATE AND APPROPRIATE SEALANT IS REQUIRED AT LOCK PENETRATIONS. WATERPROOF SEAL IS THE RESPONSIBILITY OF THE INSTALLER

② REF SHOP DWG FOR SECTION

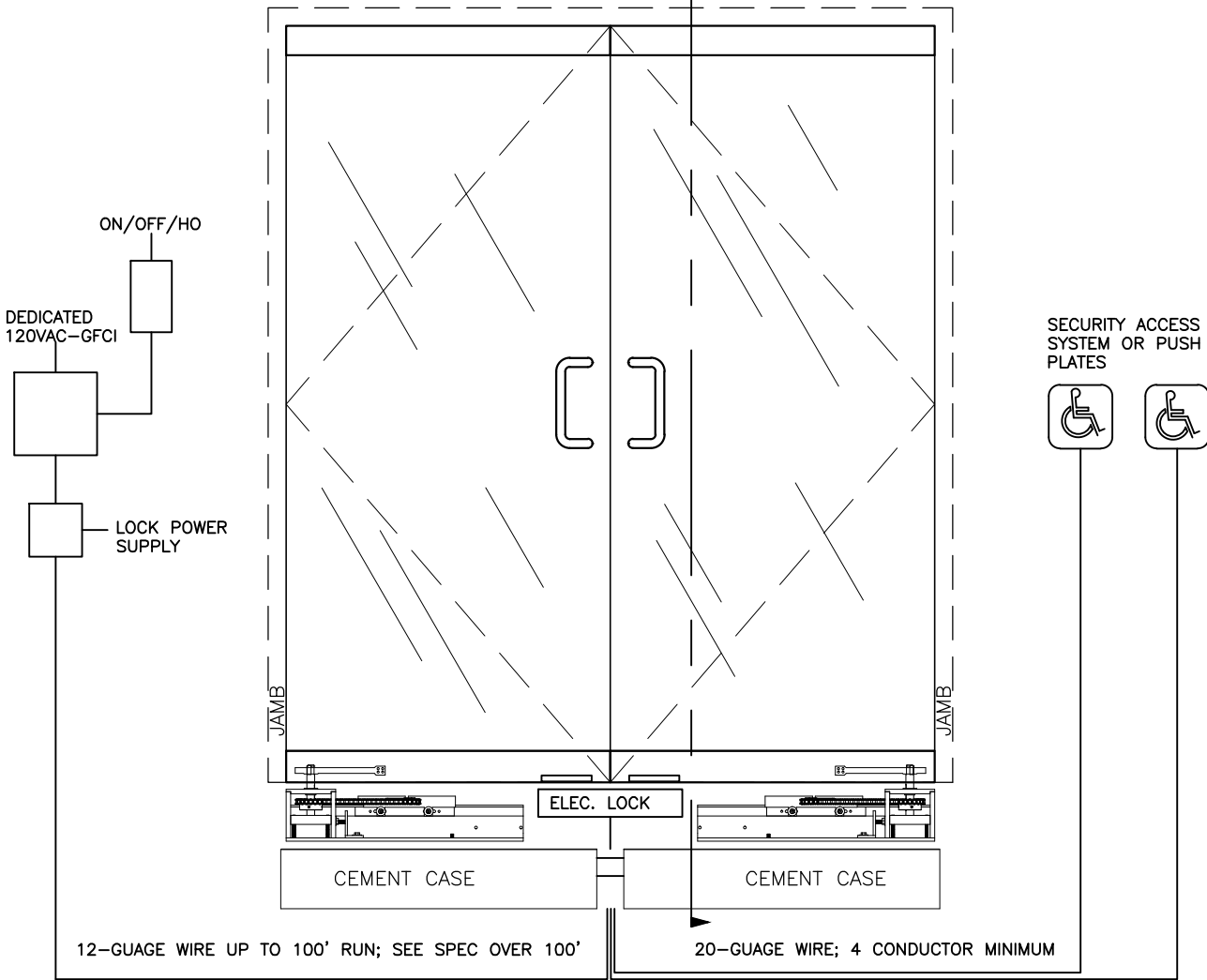

FRONT ELEVATION ③ SCALE = 1:20

CEMENT CASES SHOWN BELOW SLEDS FOR CLARITY
SINGLE DOOR WIRING SIMILAR—USE LIQUID TIGHT CONDUIT FITTINGS

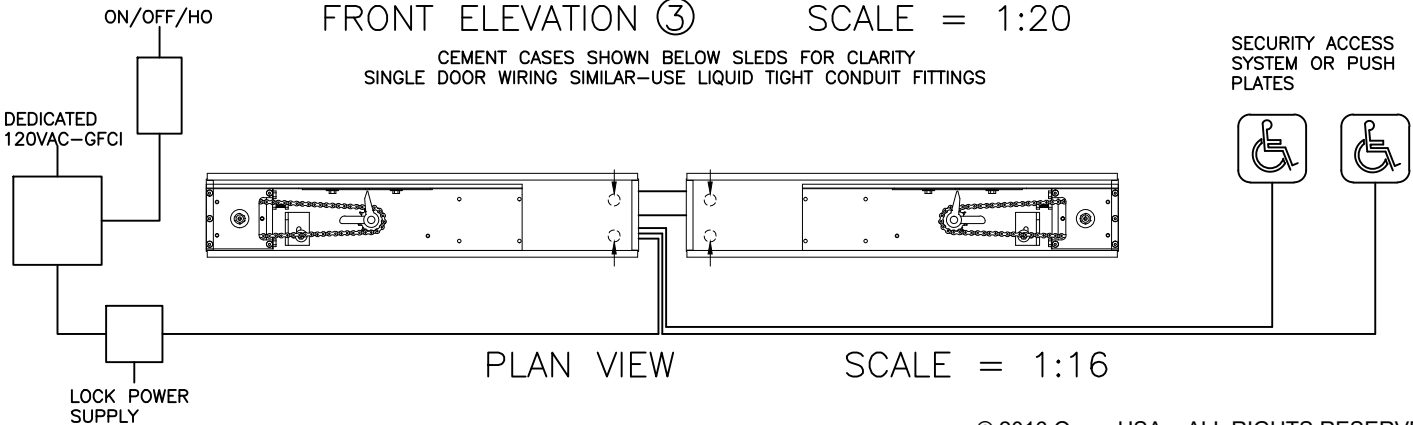

PLAN VIEW

SCALE = 1:16

OPCON USA, LP

WARRANTY POLICY ON OPCON PRODUCTS

Opcon USA, LP manufactures its products from high-grade materials utilizing only USA craftsmen. Subject to the other conditions of the warranty, if any parts of our own manufacture prove defective in material or workmanship within one (1) year after original installation, we shall repair or replace such parts free of cost. If any equipment or parts not of our own manufacture are utilized in connection with this automatic door operator conversion system, we shall assume responsibility and liability for defects only to the extent of such adjustment as the manufacturer thereof makes to us. The warranty shall not extend beyond one (1) year from the original date of installation regardless of any replacements that may be made. This is a "parts-only" replacement warranty. Field labor for warranty repairs shall be the responsibility of the installing or servicing entity.

Our obligations under the Warranty are conditional upon: (1) the owner's having filed the Warranty Registration Card with us at the time of the original installments, (2) giving us prompt written notice of alleged defects, and (3) upon our request, returning the allegedly defective items to us in Oceanside, California, freight prepaid, for inspection.

We shall have no obligation or liability, under this Warranty or otherwise, in the event of improper installation of this automatic door operator conversion system unless and until the installation is corrected. However, in no case shall we have any obligation or, liability beyond one (1) year after the original installation for any replacement or repairs that may be made. We reserve the right, without obligation, to inspect all installations of Opcon door operator conversion systems and equipment for the protection of both the owner and ourselves. Only Opcon authorized automatic door installers may install or service the Opcon conversion system and/or the interfaced automatic door operator.

In no event shall we have any obligation or liability, under this Warranty or otherwise, resulting in whole or in part from damage to defects in the door operator or equipment caused by abuse, misuse, malicious mischief, acts of God, casualty, improper handling, pressure washing at or near the equipment, installation/service by non-Opcon authorized technicians, or the negligence of the owner or others. Nor shall we have any obligations or liability for any loss, cost or expense incurred in the repair or replacement of the door operator or equipment except on express written authority from Opcon USA, LP.

The owner's sole remedy against us for any alleged defects in the Opcon Conversion System shall be as provided in the Warranty. We hereby disclaim all other obligations and liability for damages, including any incidental consequential damages. THIS PARTS-ONLY WARRANTY IS IN LIEU OF ALL OTHER WARRANTIES, EXPRESSED OR IMPLIED, INCLUDING ANY IMPLIED WARRANTY OF MERCHANTABILITY OR FITNESS FOR A PARTICULAR PURPOSE. FIELD LABOR WARRANTY IS THE RESPONSIBILITY OF THE OPCON FACTORY AUTHORIZED INSTALLER.

OPCON USA, LP

INSTALLATION GUIDELINES AFFECTING WARRANTY

The Opcon cement case enclosure is a UL 50 and CSA 22 listed and labeled, NEMA 4, water-resistant enclosure. Conformance with the following installation and service procedures must be maintained to assure a proper installation and to maintain the Opcon warranty.

1. **PENETRATIONS:** The cement case must only be penetrated to install electric power service and low voltage signal wires. The Opcon provided (and identified) liquid tight fittings must be used at both penetrations and the fittings may only be placed as detailed in the installation manual. Use of liquid tight fittings is a code requirement by the National Electric Code (NEC) and Opcon specifications. Attachments to the cement case cover are never permitted.

Please note: In certain exterior conditions (downgrade elevation, openings with direct contact to precipitation, extreme humidity or other similar conditions) a drain system or provision from the unit is recommended. In addition, the control unit should be mounted in an elevated position or remotely located separate from the unit. Condensation resulting from temperature and or climatic conditions is a naturally occurring process and not a warranty provision.

2. **SEALS:** All seals provided with the Opcon system must be installed including:
 - a. Spindle seal at aluminum cover (pressed in)
 - b. Spindle seal ("d seal") at threshold
 - c. Perimeter gasket between cement case and cover
 - d. Connector conduit and end plate seals are factory installed and sealed with a special silicone. Any damage to the silicone seal in these areas must be repaired.

SPECIAL NOTE ON SEALS: ANY SEAL FOUND TO BE DAMAGED OR WORN MUST BE REPLACED IMMEDIATELY TO MAINTAIN THE UL AND SCA LISTINGS AS WELL AS OPCON SPECIFICATIONS AND WARRANTY.

3. **FLOOR COVERS (thresholds):** All floor covers must be manufactured by Opcon or manufactured to Opcon specifications. Floor covers must be manufactured to accept all seals, must be removable for future service, and must be attached to the surrounding floor without penetrating the cement case or cement case cover. All floor covers must have a perimeter seal of silicone or similar water proofing sealant applied to keep water from encroaching between the cement case cover and the floor cover.
4. **TECHNICIANS:** The automatic operator manufacturer and Opcon must certify installation and service technicians. Additionally, technicians must be certified by the American Association of Automatic Door Manufacturers (AAADM). Installing or servicing the Opcon system or automatic operator equipment using non-certified technicians will void this warranty.
5. **PRESSURE WASHING** is never permitted at or near the Opcon installation.



3052 Industry St, Ste 104 – Oceanside, CA 92054 – (760) 720-3902 – sales@opconusa.com –
www.opconusa.com