

PTN.	DESCRIPTION
1A	CEMENT CASE
1B	SPINDLE SEAL
1C	CEMENT CASE COVER
1D	PERIMETER GASKET
1E	CASE COUPLER F/PAIRS
1F	COUPLER COVER F/SINGLES
1G	CONDUIT CONNECTOR
2A	SLED BASE
2B	MOTOR MOUNT BRACKET (2)
2C-T	FRONT PIVOT HOUSING RISER
2D-T	REAR PIVOT HOUSING RISER
2E	BASE PLATE
2F/G	TOP PLATE/LAT BUSHING
2H	LOWER TENSIONER STOP
2J	BASE PLATE BOLT (2)
2K	LATERAL WEDGES (4)
2L	LATERAL HEX WEDGE
2M	UPPER CHAIN TENSIONER
2N	WEDGE & HANDING BRACKET
3A	PIVOT ARM SPINDLE
3B	SPINDLE SPROCKET
3C	SHAFT KEY
3D-1	STD. ANTI-SLIP COLLAR F/KEY
3D-2	ALT. ANTI-SLIP COLLAR F/KEY
3E	"O" -RING
3F	BEARING COVER
3G	TAPERED BEARING
3K	THRESHOLD SEAL
3L	"O" -RING SEAL
3M	RETAINING RING
4A	DRIVE SPROCKET
4B	THRUST WASHER
4C	NEEDLE BEARING
4D	THRUST WASHER
4E	FLAT WASHER
4F	LOCK WASHER
4G	HEX BOLT
5	DRIVE CHAIN OR BELT
6	THRESHOLD ASSY.
7	OPERATOR ASSY.

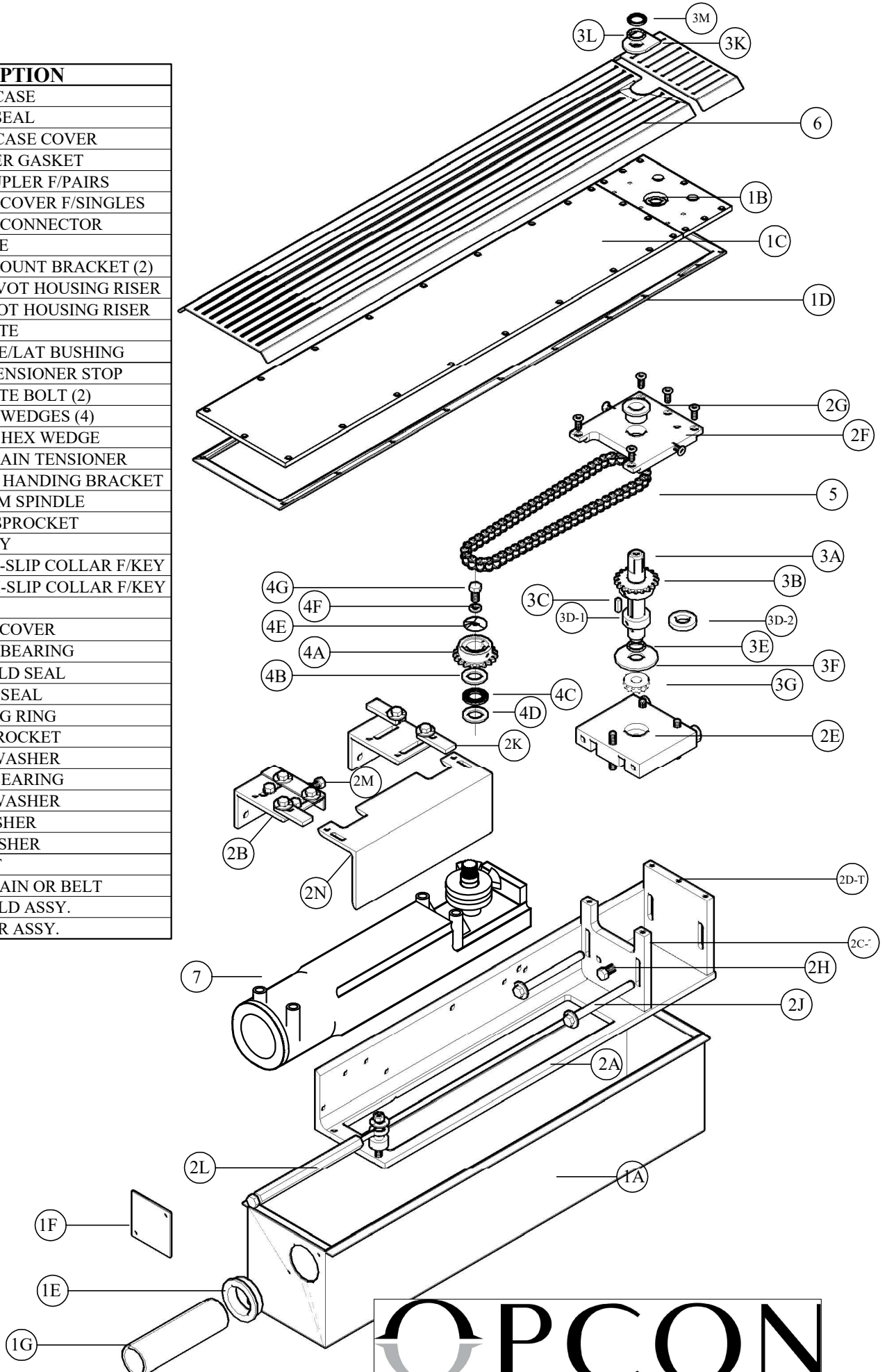

STANLEY MAGIC FORCE

© 2016 OpconUSA ALL RIGHTS RESERVED

OPCON
 . CONVERT . CONCEAL . CONNECT